



SERVICE BULLETIN No.1103

Circulate to listed addressees

COACH MODEL	: T 2100 and C2000 Series
BULLETIN TYPE	: Service Information
MANUAL & SECTION	: Maintenance Manual: Chapter 3 – Drive train Spare Parts Manual: Section 622509 – Throttle control
PARTS BOOK REVISION	: No
DATE	: March 12th, 2002
SUBJECT	: Accelerator pedal - Throttle Position Sensor
TERMS & CONDITIONS	: No claims will be accepted with reference to this Bulletin.

APPLICATION:

The service information subject of this Bulletin is applicable to units equipped with accelerator pedal VH10588255.

DESCRIPTION:

The above mentioned coaches have an electronic accelerator pedal assembly. The accelerator pedal's electronic throttle is an integral part of the engine electronic control system, and is referred to as a throttle position sensor (TPS).

The procedure in this Bulletin provides information on removal and installation of the accelerator pedal assembly, and on testing of the pedal potentiometer.

Service personnel: please read, initial and circulate.

Service Manager	Parts Manager	Warranty Administrator	Workshop Foreman	Service Technician

PARTS:

The accelerator pedal consists of an electronic throttle assembly, mounted to a foot pedal with rubber tread. The pedal assembly is secured through a hinge to the brake pedal mounting plate with screws. The throttle incorporates a spring returned roller actuating mechanism, a throttle position sensor and integrated idle validation switch, an interconnecting harness, a transmission modulator control switch (KD), and a floorplate (see Figures 1 and 2).

CAUTION: The throttle’s potentiometer and the spring roller actuator are serviceable items. However, pedal calibration may be required after repairs have been made.

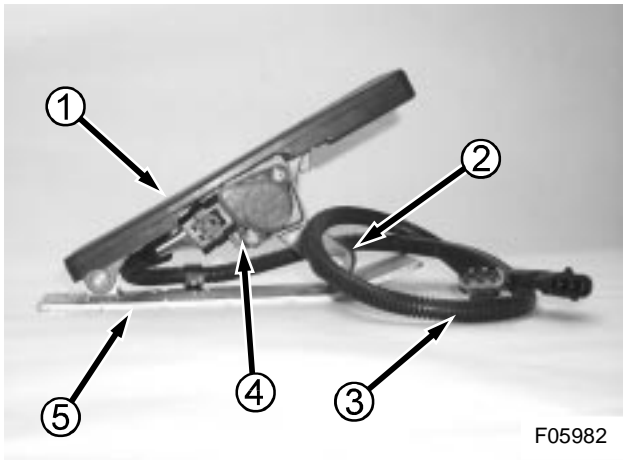

Figure 1: Accelerator pedal assembly

1. Foot pedal with rubber tread
2. Spring returned roller actuating mechanism
3. Interconnecting harness
4. Throttle position sensor with integrated idle validation switch
5. Floorplate

Part No.	Description	Qty.
VH 10588255	Accelerator pedal, complete	1
VH 10693907	Throttle position sensor	1

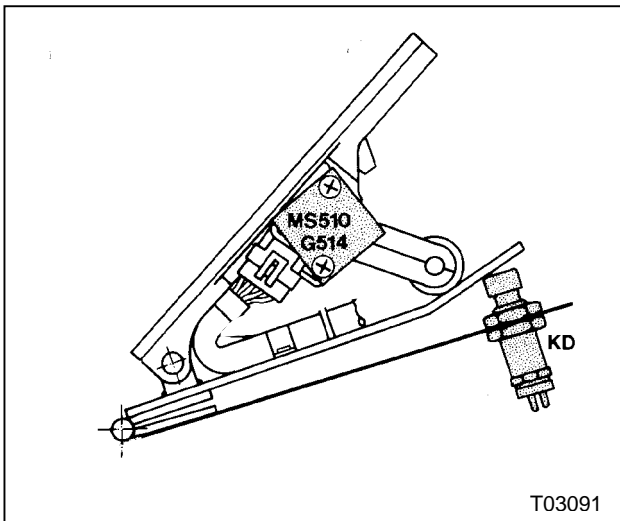

Figure 2: Accelerator pedal assembly

- G514+ MS510:** Throttle position sensor and idle validation switch
KD: Transmission modular control (kick-down)

Part No.	Description	Qty.
VH 10608112	Hinge	1
VH 660299501	Bolt, flathead M6, 6x1x15 mm	4
VH 660207414	Lock nut for 660299501	4
VH 632216017	Kick-down switch	1

- Parts may be purchased from your nearest ABC Companies Parts Source dealer.
- Always use genuine maintenance products and parts. Do not accept imitations.
- Parts disposition: discard according to applicable environmental regulations.

OPERATION:

As the pedal is pressed down, the throttle's roller and actuating lever rotates the potentiometer. The potentiometer's relative position determines the signal, which is transmitted to the engine ECM, which interprets the signal and either increases RPM when throttle is applied, or decreases engine RPM when throttle is released.

1. Throttle position sensor (TPS):

The throttle position sensor supplies a 0 to 5 VDC signal to the electronic control module (ECM) of the engine proportional to the driver's request for power.

2. Idle validation switch (IVS):

The idle validation sensor supplies a 5VDC signal to the ECM when the accelerator pedal is not in the idle position.

NOTE: The TPS and IVS are integrated into a single unit.

3. Transmission modulator control switch (Kick-Down: KD in Figure 2):

The contacts of transmission modulator control switch are closed when the pedal is in the full throttle position.

This activates the kick-down function.

NOTE:

- *Because of the different signal requirements for specific ECMs, different engine installations will require specific throttle position assemblies. Some assemblies will include an idle validation switch and additional wiring. Some may require a pulse width modulation sensor (Caterpillar).*
- *Always replace faulty sensors and/or accelerator pedals by OEM parts.*

MAINTENANCE:

- The TPS mechanism is sealed and does not require any lubrication.
- The pedal assembly and the area around the throttle's roller mechanism should be kept clean of dirt and other foreign matter.
- Inspect the pedal assembly every 24,000 miles (D interval) for excessive wear or damage. Repair/replace as necessary.

PROCEDURE (see Figure 3):

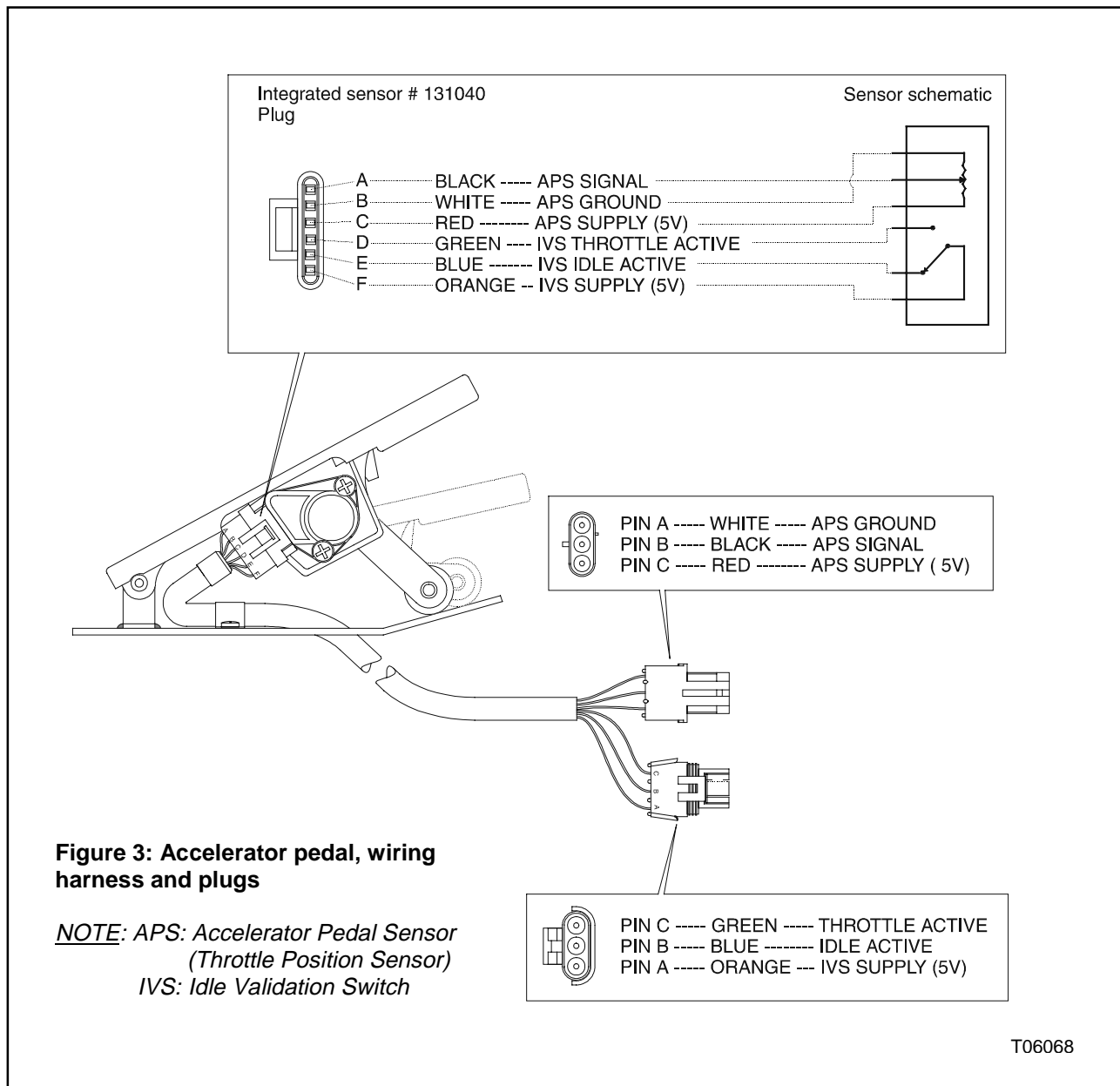

1. General:

- This job should be executed by an experienced automotive electrician.
- For more information refer to the Electrical Wiring Diagram Booklet that comes with the coach.

2. Special tools, equipment or services:

- Testing the potentiometer requires the use of a multimeter and an accelerator pedal break-out harness.

3. Preparations:

- Park the coach on a level surface, apply the parking brake and shut down the engine.
- Switch off all systems and turn off the battery master switch.
- Put a “DO NOT OPERATE” tag on the instrument panel.
- Read the entire procedure before beginning to work.

CAUTION: Observe safe shop practices at all times.

4. To remove the accelerator pedal assembly:

- 1) With the battery master switch in the OFF position, disconnect the pedal harness from the interconnecting harness.

The plugs are located:

- C2045: in the data link cabinet, to the right of the accelerator pedal.
 - T2145: above the accelerator pedal, behind the dash.
- 2) Remove the driver’s heel support by undoing the mounting screws.
 - 3) Unfasten and remove the pedal mounting screws and nuts securing the brake pedal mounting plate to the floor hinge.
 - 4) Remove the pedal assembly.

5. To install the accelerator pedal assembly:

- 1) Reinstall in the reverse order of the removal procedure.
- 2) Check accelerator pedal operation.

6. To troubleshoot the throttle position sensor (Cummins, DDEC-2, DDEC-3):

When a faulty throttle position sensor with integrated idle validation switch is suspected, proceed as follows:

Potentiometer resistance measurement

- 1) Ascertain that the ignition is OFF and disconnect the connector at the pedal mounted throttle position switch (TPS), not at some other in-line connector. Do not remove the TPS from the pedal.
- 2) Using the ohm-meter measure the end-to-end resistance of the potentiometer. This resistance should be 2.5 kOhms +/- 20%. If the resistance reading is substantially higher or lower than this value, the sensor is bad and should be replaced.

3) Measure the resistance from the wiper to each end. This measurement is to determine that the wiper is not internally shorted nor opened to one of the ends. The actual values are not really important, but should fall in the range of:

- Wiper to near end: 100 to 600 Ohms.
- Wiper to far end: 1,600 to 2,200 Ohms.

The reason for the wide variation is the +/-20% tolerance of the potentiometer and the tolerance of the mechanical pedal parts. If a short (0 Ohms) or an open (infinite Ohms) is found, the sensor is bad and should be replaced.

IVS resistance measurement

***NOTE:** Cummins engines (CELECT, CELECT Plus, ISM, ISB and ISL) require both Idle Active and Throttle Active outputs from the IVS. Detroit Diesel engines require Idle Active only.*

- 1) With the pedal in the Closed Throttle (CT) position, measure the resistance between the IVS supply pin and the Idle Active output pin. The values should be 20 to 125 Ohms.
- 2) With the pedal in the Closed Throttle (CT) position, measure the resistance between the IVS supply pin and the Throttle Active output pin. The values should be infinite Ohms.
- 3) Depress the pedal to Wide Open Throttle (WOT) position and measure the resistance between the IVS supply pin and the Throttle Active pin. The values should be 20 to 125 Ohms.
- 4) With the pedal in the Wide Open Throttle (WOT) position, measure the resistance between the IVS supply pin and the Idle Active output pin. The values should be infinite Ohms.

If either section of the IVS switch reads above 125 Ohms in the made position, or reads less than 10Mohms in the off position, the Integrated Sensor is bad and should be replaced.

Potentiometer voltage measurement

- 1) With the TPS connector still disconnected, switch ON the ignition but do not attempt to start the engine. Measure the voltage between TPS Vref(+) and TPS ground coming from the vehicle. The voltage value read should be 4.75 to 5.25 Volts.

If the voltage measured is outside these limits the problem is not in the TPS. Do not replace the sensor: troubleshoot towards the ECM.

- 2) Switch OFF the ignition, connect the sensor to the vehicle harness with the brake-out harness in-line and switch ON the ignition again. The following voltage measuring procedures are the key to determining if the sensor is bad, or if the problem is elsewhere in the system.

In each case, the first step is to measure and record TPS Vref. All measurements are with respect to TPS ground, NOT chassis ground. A percentage of this number, as opposed to absolute volts, will be used to determine status of the TPS.

The measurement technique is the same for each type of sensor:

1. With the pedal in the CT position, measure the voltage at the TPS output pin. Record the voltage.
2. With the pedal in the WOT position, measure the voltage at the TPS output pin. Record the voltage.
3. Calculate CT percent of Vref (divide CT position TPS voltage by Vref voltage and multiply that result by 100).
4. Calculate WOT percent of Vref (divide WOT position TPS voltage by Vref voltage and multiply that result by 100).
5. Calculate range percent of Vref (subtract CT% from WOT%).
6. Compare the values measured to the corresponding ones in the table below. If the measured are outside the stated limits, the sensor is bad and should be replaced. If the measured values fall within the spec limits, do not replace the sensor: troubleshoot towards the ECM.

Engine/ Throttle pos.	DDEC-2	DDEC-3	CELECT	CELECT+
CT	8% to 12%	10% to 20%	5% min	5% min
WOT	83% to 92%	70% to 85%	81% max	81% max
Range	71% to 84%	60% to 75%	60% to 75%	60% to 75%

IVS voltage measurement

The break-out box allows voltage measurement of the IVS.
Measure:

- 1) Supply voltage, between pins B and F: 4.75 to 5.25 volts.
- 2) With the pedal at CT:
 - Idle Active, between pins B and E: at least 4.25 volts.
 - Throttle Active, between pins B and F: less than 0.5 volts.
- 3) With the pedal at WOT:
 - Idle Active, between pins B and E: less than 0.5 volts
 - Throttle Active, between pins B and F: at least 4.25 volts.

If any of the voltages are out of specification, but the resistances measured were correct, then the problem is not in the TPS. Do not replace the sensor: troubleshoot towards the ECM.

To replace the TPS

If the TPS requires replacement, proceed as follows:

- 1) Turn off the ignition and battery master switch.
- 2) Remove the wiring harness connector and the two TPS mounting screws.

- 3) Remove the TPS.
- 4) Align the new TPS with the rectangular tab which drives the TPS.
- 5) Start the TPS into the TPS centering hole.
- 6) Rotate the TPS to align the mounting screw holes.
- 7) Seat the TPS into the centering hole.
- 8) Tighten the screws to 10 to 20 in.lbf.
- 9) Reconnect the wiring harness connector.

7. To calibrate the accelerator pedal assembly:

The ECM and accelerator pedal must be calibrated when an accelerator pedal is initially installed, when an accelerator pedal is replaced, when a new calibration is downloaded to the ECM, and when the accelerator pedal wiring is being disconnected while the vehicle ignition switch is ON.

To recalibrate the ECM and accelerator pedal, the ignition switch must be in the ON position and then the accelerator pedal must be slowly and fully depressed from idle to full throttle. Repeat the procedure three times.

Procedure complete.

SERVICE INFORMATION:

Service Bulletins are issued to supplement or supersede information in the Van Hool manuals. Note Service Bulletin number, date and subject on the register at the end of the relevant chapter(s). File Service Bulletin separately for future reference.