



Service Bulletin No. 1063

COACH MODEL	: T2100 Series
BULLETIN TYPE	: Service information
MANUAL & SECTION	: Maintenance Manual : Chapter 10 - HVAC System Chapter 12 - Maintenance Schedule of Appendices
DATE	: January 31st, 2001
SUBJECT	: Corrosion of front unit flap actuator pivot point
TERMS & CONDITIONS	: No claims will be accepted with reference to this Bulletin.

DESCRIPTION:

There are specific service requirements for the T2100 fresh air flaps. Every 60,000 miles, during the HVAC E type maintenance interval, air flap operation needs to be checked. This includes the roof top flaps, but also the flap of the front unit. For the latter, particular attention should be paid to the upper pivot point of the flap actuator (see Figure 1), which is located just behind the trim moulding between the headlights. In spite of a rubber shield fitted in front of the actuator, this pivot point has been known to corrode on earlier coaches, preventing proper operation of the flap. On later coaches the low carbon steel pivot has been replaced by a stainless steel one to eliminate this problem. The guidelines below explain how corroded pivots can be treated.

SERVICE PROCEDURE:

!!!CAUTION!!!

**OBSERVE SAFE SHOP PRACTICES AT ALL TIMES.
READ ENTIRE PROCEDURE BEFORE BEGINNING TO WORK.**

1. At the front of the coach, with a 5 mm Allen key, undo the three hex socket head bolts securing the trim moulding between the head lights to the chassis.

Service procedure continued on next page

Service Bulletins are issued to supplement or supersede information in the Van Hool manuals. Note Service Bulletin number, date and subject on the register at the end of the relevant chapter(s). File Service Bulletin separately for future reference.

K:\SERVICE\USA\PM\SB#\SB1063

Continued from page 1

Lift the moulding from its support brackets.

2. Lubricate the upper actuator pivot point generously with penetrating oil, such as CRC or WD40, and allow to work in.
3. Operate the flap of the front unit a couple of times by means of the air flap control switch on the instrument panel to free the pivot.
4. Undo and remove the self-locking nut and plain washer of the lower actuator pivot point with a 10 mm box wrench.
5. Carefully remove the actuator from both pivot points.
6. Remove all corrosion from the upper pivot point with emery cloth and penetrating oil.
7. Repeat step 6 for the pivot hole in the actuator pushrod.
8. Grease the upper pivot point with Molycote GN+.
9. Refit the actuator with the pushrod pointing up.
10. Refit the plain washer and self-locking nut to the lower pivot point. Tighten for a loose fit.
11. Refit the trim moulding between the head lights.

Service procedure complete.

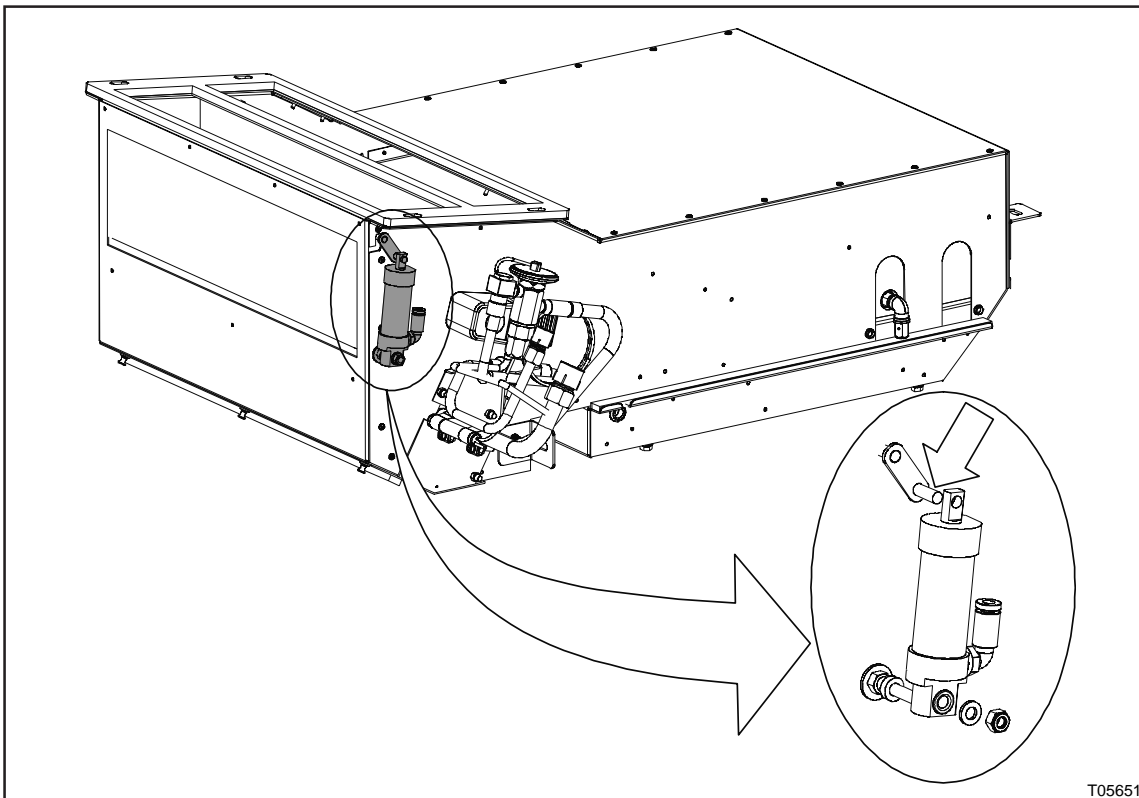

Figure 1 : Front unit with fresh air flap actuator and pivot points

K:\SERVICE\USA\PM\SB#\SB1063