



Service Bulletin No. 1076

COACH MODEL	: T800 Series, T900 Series, T2100 Series, C2000 Series
BULLETIN TYPE	: Product improvement
MANUAL & SECTION	: Maintenance Manual : Chapter 10 - HVAC system
DATE	: May 31st, 2001
SUBJECT	: Introduction of a new O5G compressor crankshaft seal
TERMS & CONDITIONS	: No claims will be accepted with reference to this Bulletin.

APPLICATION :

All.

DESCRIPTION :

Ref. : Carrier/Sütrak Technical Bulletin GB 99-001
 Carrier/Sütrak Technical Bulletin GB 98-009
 Carrier Service Information # 092900

In an effort to improve the O5G compressor service life, Carrier/Sütrak have released a redesigned crankshaft seal assembly, which has been introduced in new compressors starting with serial number 4198J00661 ; and replacement compressors starting with serial number 1699Maxxxx. Compressor serial numbers are stamped on the compressor identification plate, which is located below the left-hand cylinder bank.

The compressor seal assembly consists of a springloaded bellows, a carbon washer, a wear ring, an O-ring and a steel gasket. The springloaded bellows contained in new seal package #17-44145-00 is a three-piece unit, which will be supplied fully assembled only. The individual parts will not be available separately. The new seal package, which includes fitting instructions, will automatically replace the old 17-44130-00 package. The seal bellows and carbon washer remain unchanged.

Should a seal assembly need replacing, always replace the complete assembly. For more information on compressor crankshaft seals refer to Carrier transicold service training manual # 62-50400-01.

Service Bulletins are issued to supplement or supersede information in the Van Hool manuals. Note Service Bulletin number, date and subject on the register at the end of the relevant chapter(s). File Service Bulletin separately for future reference.

K:\SERVICE\USA\PM\SB#\SB1076LH

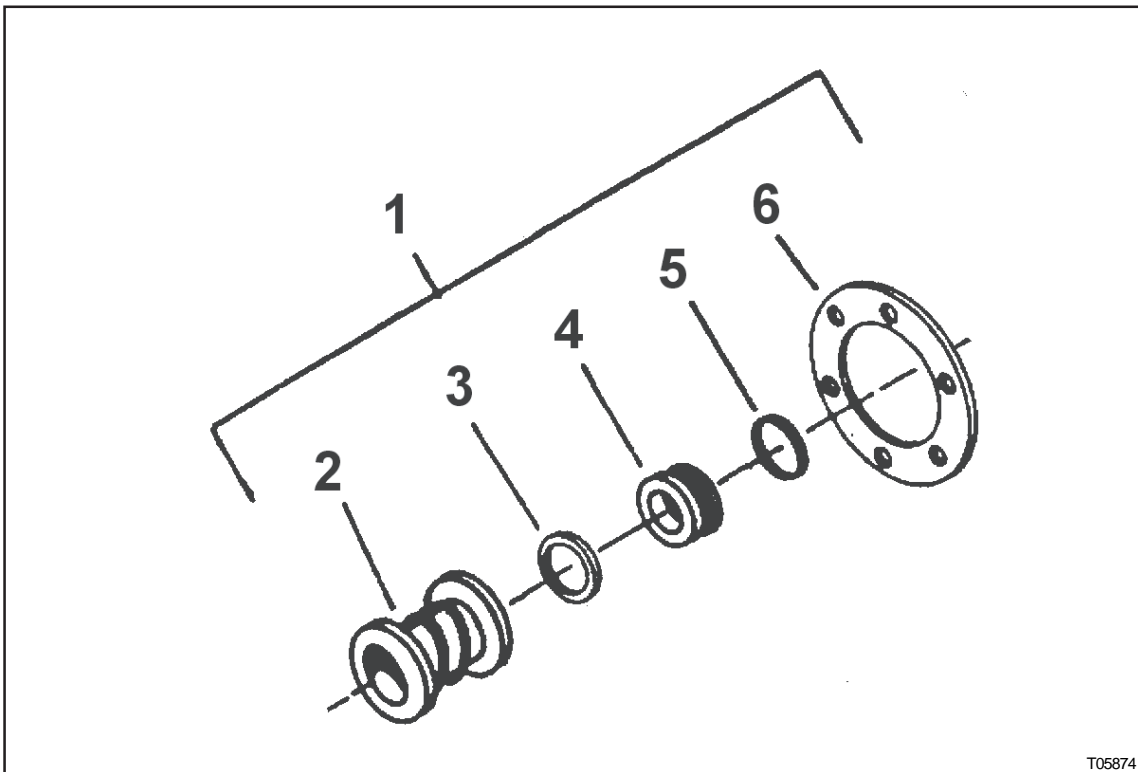

T05874

Figure 1: Compressor crankshaft seal assembly for housing mounted clutch

PARTS :

1. Parts may be purchased from your nearest Carrier Service Outlet.
2. New parts are directly interchangeable with old parts. Only new parts will be offered for service replacement.

SERVICE INFORMATION :

1. Van Hool use HMC (Housing Mounted Clutches) on their compressors. Note that the seal assembly for this type of clutch differs from the one found on a shaft mounted clutch.
2. Fundamental crankshaft seal features :
 - The crankshaft is sealed by an axial face seal (stuffing box end)
 - The sealing surface is subject to gliding friction, therefore the rotating sealing surfaces have to be lubricated.
 - The compressor oil produces a thin lubricating and sealing film, preventing at the same time the loss of refrigerant.
3. During the running-in period some oil may seep outside the compressor, producing oil drops. This does not mean the crankshaft seal is not tight. So there is no need to replace it. After a running-in period of about 200 to 300 working hours, the seal

K:\SERVICE\USA\PmSB#\SB1076LH

will work normally. Oil leakage of up to about 0.77 drop (0.05 cm³) per working hour can be considered acceptable.

4. Shaft seals may be damaged because of the following :

- Thermal overload. When the compressor has been overheated, the O-ring and the sealing surfaces will be damaged.
- Frequent on and off switching within short intervals.
- Long inoperative periods. Sticking seals may become damaged, when the compressor is used again.
- Dirt and debris scoring the high-finish sealing surfaces.
- Copper cladding due to moisture in the refrigerant circuit.

5. When replacing the crankshaft seal :

- Extreme cleanliness should be observed.
- Replace the seal only as a complete unit.
- Clean all sealing surfaces.
- Oil the O-ring and the sealing surfaces.
- Center the seal cover with the centering sleeve.
- Tighten the screws evenly and to the correct torque figure.

6. If the crankshaft seal needs replacement frequently without acceptable results and without visible damage to the seals, the entire compressor should be replaced (knocked-out main bearing ; crankshaft damaged at O-ring sealing surface).

Service Information complete.

THIS PAGE HAS BEEN LEFT BLANK INTENTIONALLY