



Service Bulletin No. 1065

COACH MODEL	: T2100 Series
BULLETIN TYPE	: Product improvement
MANUAL & SECTION	: Maintenance Manual : Chapter 4 - Axles, wheels and tires Chapter 12 - Maintenance schedule Spare Parts Manual : Section 642006, 642106, and 642206
DATE	: January 31st, 2001
SUBJECT	: Unitized hub design wheel bearing units on coaches with D-ELSA disc brakes
TERMS & CONDITIONS	: Parts may be purchased from your nearest International Coach Parts Inc. dealer. Note that no claims will be accepted with reference to this Bulletin.

DESCRIPTION:

Following the introduction of D-ELSA disc brakes, unitized maintenance-free wheel bearing units have been cut into production on the front, drive and tag axles effective as from units :

T2145 Cummins	T2145 Detroit Diesel	Axle
VIN 44055	VIN 43945	Front and tag axle
VIN 44123	VIN 43991	Drive axle

For front and tag axle applications, the new design combines eleven conventional components in one: hub, seals, grease, two cups and cones, bearing spacer ring, and the ABS/ASR impulse ring, giving several important advantages :

1. There is no need for neither bearing adjustment nor greasing, as unitized wheel bearing units are adjusted, greased and sealed for life.
2. During disc brake service the unit stays undisturbed on the axle, which eliminates the three most common causes for premature failure of the classic wheel bearings :
 - seal damage resulting in loss of bearing lubricant and water ingress.
 - introduction of contamination in the bearing during the dismantling and refitting causing wear to the precision-finish of the working surfaces of raceways and rollers.
 - incorrect assembly and bearing end-play adjustment after refitting.

Service Bulletins are issued to supplement or supersede information in the Van Hool manuals. Note Service Bulletin number, date and subject on the register at the end of the relevant chapter(s). File Service Bulletin separately for future reference.

K:\SERVICE\USA\PmSB#\SB1065

For drive axle applications the unitized bearing unit is a sub-assembly of the hub and comes without an ABS/ASR pulse ring, the ring being cast into the brake disc. During brake disc replacement, the hub and unitized bearing unit can be removed from the axle without disassembling the bearings or touching the seals.

This Bulletin compares the new with the classic bearing set-up. It also provides the necessary service procedures to check wheel bearing end-play, and to remove and install the integral hub units of all three axles.

PARTS :

Always use genuine maintenance products and parts. Do not accept imitations.

Part No.	Description	Qty.*
VH10599854	Hub unit, unitized, front and tag axle	2
VH10720826	Hub unit, unitized, drive axle	2
VH10554144	Hub nut, front and tag axle	2
VH10720827	Hub nut, drive axle	2
VH10554118	Washer, front and tag axle	2

* Quantities per axle

SERVICE PROCEDURE :

1. Comparison - classic v. unitized wheel bearing set-up :

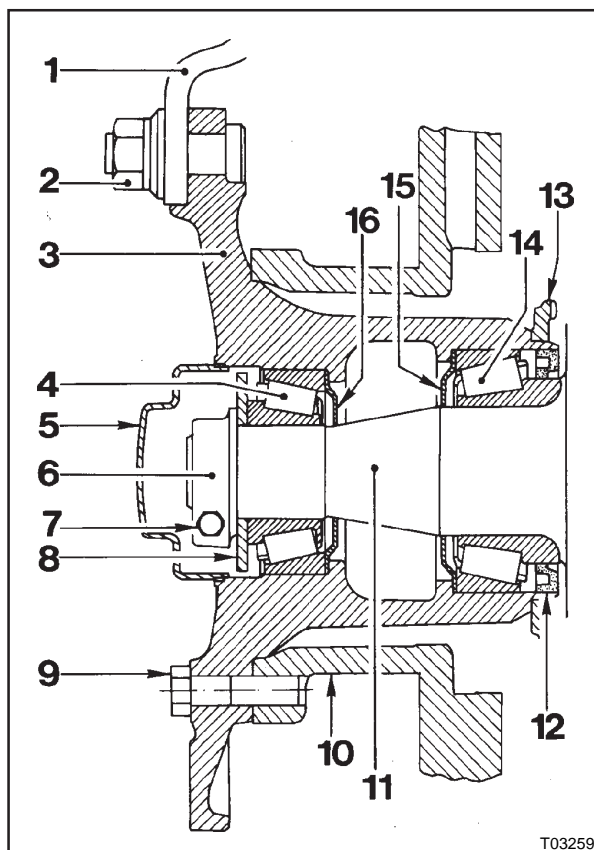

Figure 1 : Classic wheel bearing set-up (front and tag axle installation)

1. Wheel
2. Wheel nut
3. Hub
4. Outer roller bearing
5. Hub cap
6. Hub nut
7. Hub nut pinch screw
8. Washer
9. Screws securing brake disc to hub
10. Brake disc
11. Steering knuckle spindle
12. Grease seal
13. ABS/ASR impulse ring
14. Inner roller bearing
15. Inner grease retaining disc
16. Outer grease retaining disc

- Requires repacking every 120,000 miles.
- Disassembly of brakes requires hub and bearing removal.

K:\SERVICEUSA\pmsb\SB1065

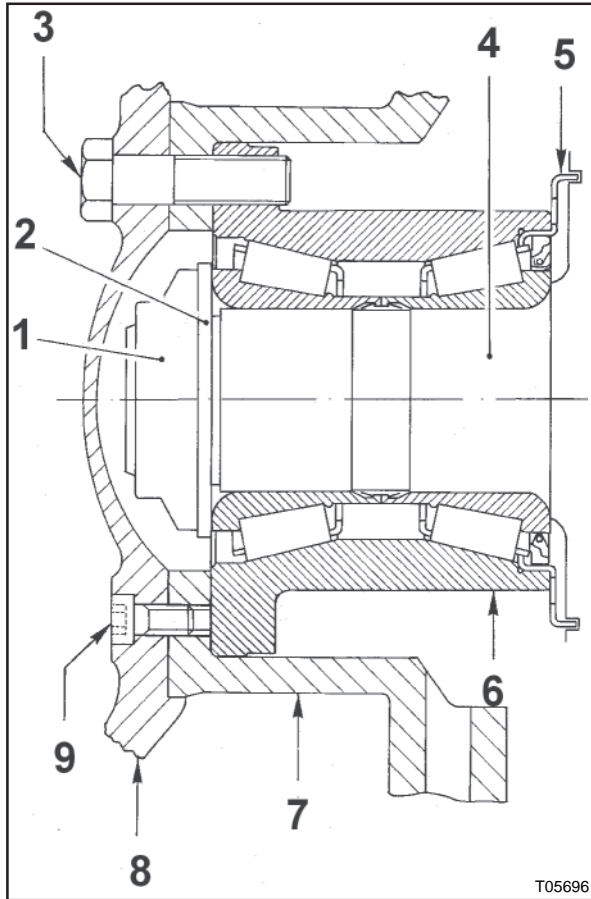

Figure 2 : Unitized hub bearing set-up (front and tag axle installation)

1. Hub nut
2. Washer
3. Screws securing brake disc and wheel flange to hub unit
4. Stub axle spindle
5. ABS/ASR impulse ring
6. Hub unit
7. Brake disc
8. Wheel flange
9. Socket screw

- Needs checking for end-play every 120,000 miles.
- No adjustment required.
- Sealed and lubricated for life.
- During disc brake service the unit stays on the axle.

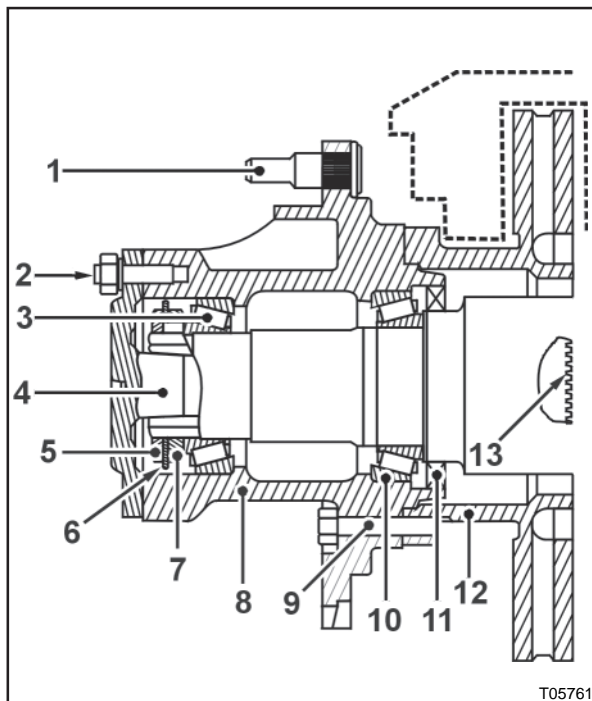

Figure 3 : Classic wheel bearing set-up (drive axle installation)

1. Lug stud
2. Half shaft flange stud and nut
3. Outer bearing
4. Half shaft
5. Jam nut
6. Locking ring
7. Adjuster nut and dowel
8. Hub
9. Hub to brake disc bolt
10. Inner bearing
11. Seal assembly
12. Brake disc
13. ABS/ASR impulse ring

- Disassembly of brakes requires hub and bearing removal.

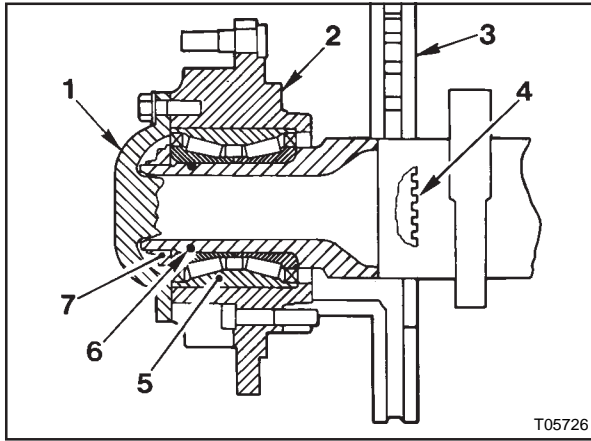

Figure 4 : Unitized hub bearing set-up (drive axle installation)

1. Half shaft flange
2. Hub
3. Brake disc
4. ABS/ASR impulse ring
5. Unitized hub bearing
6. O-ring
7. Hub nut

- No adjustment required.
- Sealed and lubricated for life.

2. Unitized hub unit maintenance intervals :

Every 120,000 miles (F-interval), or at least once a year :

- Check wheel bearing end play : maximum 0.01 inch (0.25 mm).

3. Unitized hub unit service (front and tag axle) :

CAUTION

OBSERVE SAFE SHOP PRACTICES AT ALL TIMES.
READ THE ENTIRE PROCEDURE BEFORE BEGINNING TO WORK.

To replace hub grease

The unitized hub bearing units are lubricated for life.

To check the wheel bearing end-play

NOTE

Bearing end-play is not adjustable. Replace the entire hub bearing unit, if the measured value is out-of-limit.

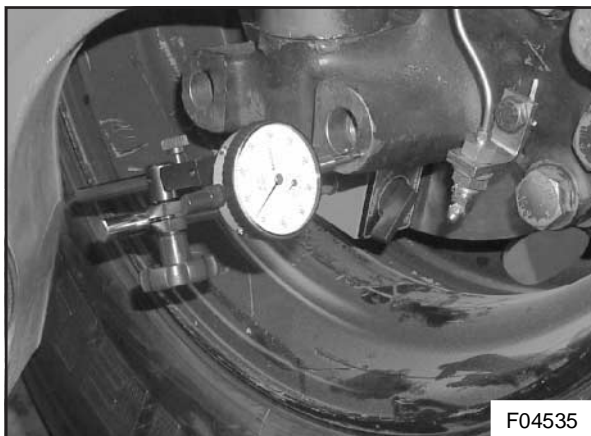

Figure 5 : Correct dial indicator position

K:\SERVICE\USA\PmSB#SB1065

1. Before lifting the coach, chock the road wheels which will remain on the work floor. Apply the parking brake and jack-up the coach at the recommended jacking points, until the wheel which needs to be checked clears the ground.
2. Attach a dial indicator with a magnetic stand to the inside flange of the brake disc. Position the stylus of the dial indicator at a right angle to the brake disc against the machined face of the lower steering knuckle yoke, near the frontmost threaded hole (see Figure 5).
3. Take a firm grip on the roadwheel and alternately rock it forwards and backwards (in the vertical plane).
4. Have an assistant take note of the total variation shown by the indicator, which should be maximum 0.01 inch (0.25 mm).

To remove the hub unit (see Figure 3)

NOTE
<i>The unitized hub bearing unit combines as major parts two bearings, two grease seals and an ABS/ASR impulse ring. If one of these components is damaged, the complete unit must be replaced by a new one.</i>

1. Before lifting the coach, chock the road wheels which will remain on the work floor. Apply the parking brake and jack-up the coach at the recommended jacking points, until the road wheel which needs to be removed clears the ground. Install safety blocks under the chassis members. Remove the road wheel and pull back the ABS/ASR sensor.

CAUTION
THE COMPONENTS WHICH NEED TO BE REMOVED HAVE A CONSIDERABLE WEIGHT. TO AVOID PERSONAL INJURY AND/OR DAMAGE TO THE VEHICLE OR COMPONENT, MAKE SURE THE PART IS WELL SUPPORTED, BEFORE ANY FASTENERS ARE REMOVED.

CAUTION
ALWAYS HANDLE FRONT AND TAG AXLE UNITIZED BEARINGS WITH GREAT CARE. DO NOT ALLOW ANYTHING TO TOUCH THE ABS/ASR IMPULSE RING. ANY DAMAGE TO THE RING MAY CAUSE THE ABS/ASR CONTROL UNIT TO OPERATE ERRATICALLY.

2. Remove the brake caliper/carrier assembly.
3. Undo and remove socket screw #9.
4. Undo and remove the twelve screws #3 securing the wheel mounting flange and brake disc to the hub unit.

K:\SERVICE\USA\PM\SB#\SB1065

5. Remove wheel mounting flange #8.
6. Run pusher screws into the three M12x1.5 threaded holes to separate the brake disc from the hub unit. Remove the brake disc.
7. Undo hub nut #1 using the socket shown in Figure 6. Remove washer #2.

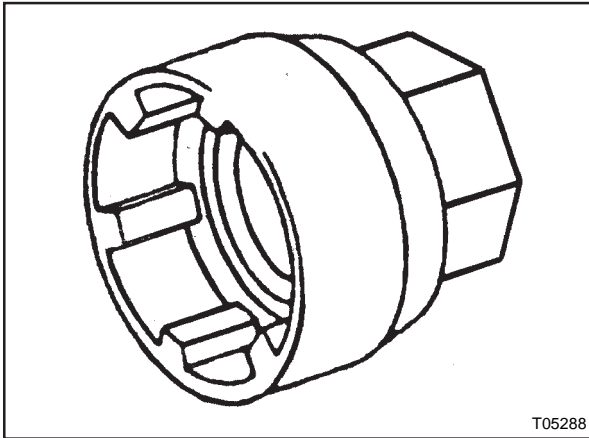

Figure 6 : Hub nut socket VH A996030253

8. Use the tool set shown in Figure 7 to remove the hub unit.

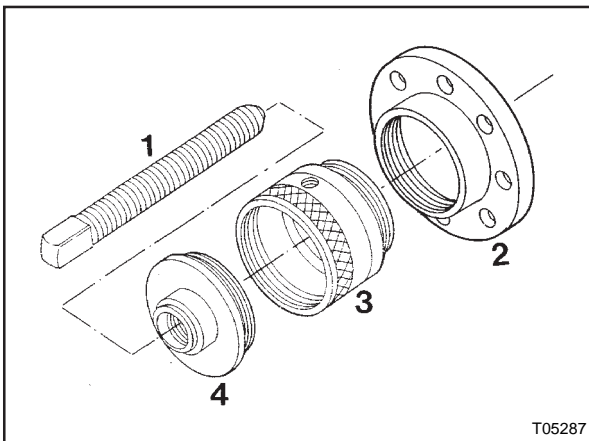

Figure 7 : Tool set to remove hub unit

1. Spindle VH No. A996060240
2. Flange VH No. A996060464
3. Threaded bush VH No. A996060251
4. Cover VH No. A996060238

Procedure :

- a. Secure flange #2 to the hub unit with three screws.
- b. Screw threaded bush #3 into flange #2.
- c. Screw cover #4 into threaded bush #3.
- d. Screw spindle #1 into cover #4.
- e. Remove the hub unit by turning spindle #1 clockwise.

To install the hub unit (see Figure 3)

1. Thoroughly clean axle spindle #4 and apply a thin film of Never-Seez.
2. Use the tool set from Figure 8 to install the hub unit.

K:\SERVICEUSA\PM\SB#\SB1065

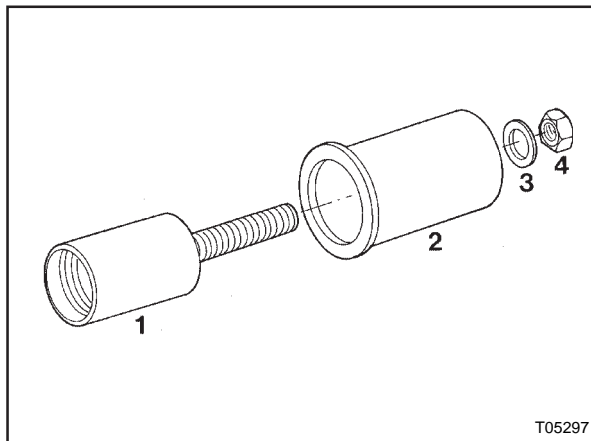

Figure 8 : Tool set VH No. 10678700 to install hub unit

Procedure :

- a. Screw guide bush #1 onto the steering knuckle spindle.
 - b. Slide the hub unit on bush #1.
 - c. Slide press bush #2 on guide bush #1
 - d. Install washer #3 and nut #4 on the threaded rod of guide bush #1.
 - e. Turn nut #4 clockwise to install the hub unit on the steering knuckle spindle.
 - f. Remove the tools.
3. Install washer #2. Install hub nut #1. Tighten the hub nut to a torque of 515 to 575 ft.lbf (700 to 780 Nm) and simultaneously rotate the hub in both directions to settle the hub bearings. Carefully push back the ABS/ASR sensor, until it touches the impulse wheel.
 4. Apply a thin film of NLGI No. 2 grade high temperature lithium grease to the contact surfaces between brake disc #7 and hub unit #6.
 5. Put brake disc #7 on a flat surface. Position wheel flange #8 on top of brake disc #7 so that the small hole in the flange aligns with the small threaded hole in the disc. Secure wheel flange #8 to brake disc #7 with socket screw #9. Tightening torque 48 to 62 ft.lbf (65 to 85 Nm). Install the wheel flange/brake disc assembly on the hub unit aligning the holes in the assembly with the threaded holes in the hub unit. Install screws #3 and tighten them crosswise in steps to a torque of 300 to 340 ft.lbf (400 to 460 Nm).
 6. Reinstall the brake caliper/brake carrier.
 7. Install the road wheel and tighten the wheel nuts to a torque of 435 to 465 ft. lbf (580 to 620 Nm).

K:\SERVICE\USA\PM\SB#\SB1065

4. Unitized hub unit service (drive axle) :

To remove the hub and unitized bearing assembly (see Figure 4)

1. Chock the road wheels of front and tag axle. Apply the parking brake and jack-up the coach at the recommended jacking points to lift the drive axle. Support the drive axle at the C-beams with axle stands. Remove the road wheels.
2. Although the parking brake will hold the brake rotor in place, install a hard wooden block about $\frac{5}{8}$ inch (16 mm) thick in the gap between the brake disc and the top of the axle housing as a precaution.
3. Install a drip pan below the hub to catch spilled oil.
4. Undo and remove the halfshaft flange bolts. Remove the halfshaft.
5. Mark the position of the brake disc to the hub.
6. Undo and remove the hub to disc Allen bolts.
7. Undo and remove the hub nut.
8. Pull the hub from the spindle.
9. Remove the unitized bearing unit from the hub with a press.
10. Remove the O-ring from the drive axle spindle (see Figure 9).

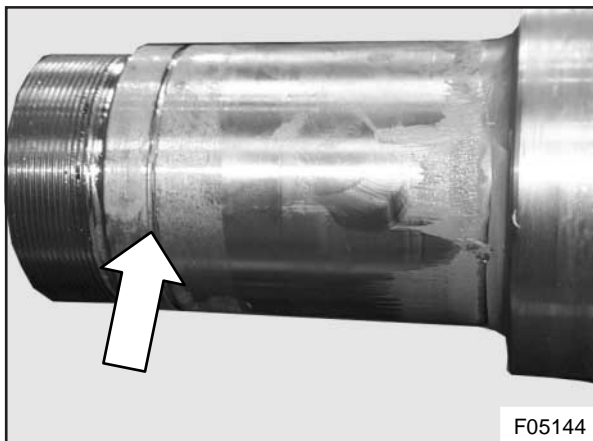

Figure 9 : O-ring groove on drive axle spindle

To install the hub and unitized bearing assembly (see Figure 4)

1. Install a new unitized bearing into the hub using a press.
2. Thoroughly clean the axle spindle, fit a new O-ring and apply a thin film of Never-Seez.
3. Install the hub on the axle spindle.

K:\SERVICEUSA\PmSB#SB1065

4. Run up the hub nut for a loose fit.
5. Align the hub with the brake disc. Secure the hub to the brake disc with the Allen bolts and tighten crosswise in steps to a torque of 205 to 225 ft.lbf (275 to 305 Nm).
6. Tighten the hub nut to a torque of 260 to 295 ft.lbf (350 to 400 Nm).
7. Rotate the hub ten revolutions to settle the bearings.
8. Finally tighten the hub nut to a torque of 660 ft.lbf (900 Nm).
9. Apply Loctite 518 to the mating surfaces of the half shaft flange and the hub. Install the axle shaft and tighten the half shaft retaining screws to a torque of 265 to 295 ft.lbf (360 to 400 Nm).
10. Remove the wooden block from between the brake disc and the top of the drive axle housing.
11. Remove the drip pan and refit the road wheels. Tighten the wheel nuts to a torque of 435 to 465 ft.lbf (580 to 620 Nm).
12. Add fresh differential oil as required.
13. Remove the axle stands, lower the coach and remove the wheel chocks.

5. Unitized hub unit service precautions (front axle) :

The following precautions should be taken, when the front axle is being serviced to ensure proper operation of the ABS system and to avoid costly repairs:

1. When working on the steering system, remove the ABS/ASR wheel speed sensor before disassembling the steering arms to prevent damage to the sensor and the ABS/ASR impulse ring.
2. If the steering knuckle is rotated towards the back of the coach through an angle of about 90° with the steering arms removed, the steering knuckle carrier will knock the ABS/ASR sensor against the ABS/ASR impulse ring, and damage both.
3. This mechanical damage is only visible with the integral hub unit removed from the knuckle spindle and causes the ABS/ASR control unit to operate erratically.
4. Since the ABS/ASR impulse ring is an integral part of the hub assembly, the whole unit needs to be replaced, when the ring is damaged.

5. The proper procedures to service the front axle equipped with D-ELSA disc brakes have been published in the Maintenance Manual.

NOTE

Proper care should also be taken during handling and storage of the integral wheel bearing and hub unit to prevent damage to the ABS/ASR impulse ring.

Service procedure complete.