



SERVICE BULLETIN No.1112

For ABC Customer Care & Parts Source-staff only
Do not circulate to listed addressees

COACH MODEL	: T2145 w/ ADA lift
BULLETIN TYPE	: Field Change Program
MANUAL & SECTION	: Maintenance Manual: Chapter 10 – HVAC System Spare Parts Manual: Section 771609 - Ventilation
PARTS BOOK REVISION	: Yes
DATE	: January 10th, 2003
SUBJECT	: Rear quarter ventilation
TERMS & CONDITIONS	: Parts and labor allowance will be provided as per warranty information in this Bulletin.

APPLICATION:

The T2145 units mentioned below may be retrofitted according to the production changes described in this Bulletin:

Model	Engine	VIN units built 1999 - 2000	VIN units built 2001
T2145 + Lift	Cummins	44096 → 44100, 44102, 44111 & 44132	44261 → 44265
	Detroit Diesel	43963, 43964, 43997, 44521, 44522	44566 & 44567

DESCRIPTION:

Modifications have been made regarding the location and type of air outlets used at the rear of the passenger compartment of T2100 coaches equipped with an ADA lift. The changes were cut into production to:

- Improve air distribution in the lift door area.
- Provide forced ventilation in the restroom.

This Bulletin provides information on the latest rear ventilation status, and includes a diagram and photos with the current air outlet locations. A procedure to retrofit units in the field is also provided.

Description continued on next page.

Service personnel: please read, initial and circulate.

Service Manager	Parts Manager	Warranty Administrator	Workshop Foreman	Service Technician

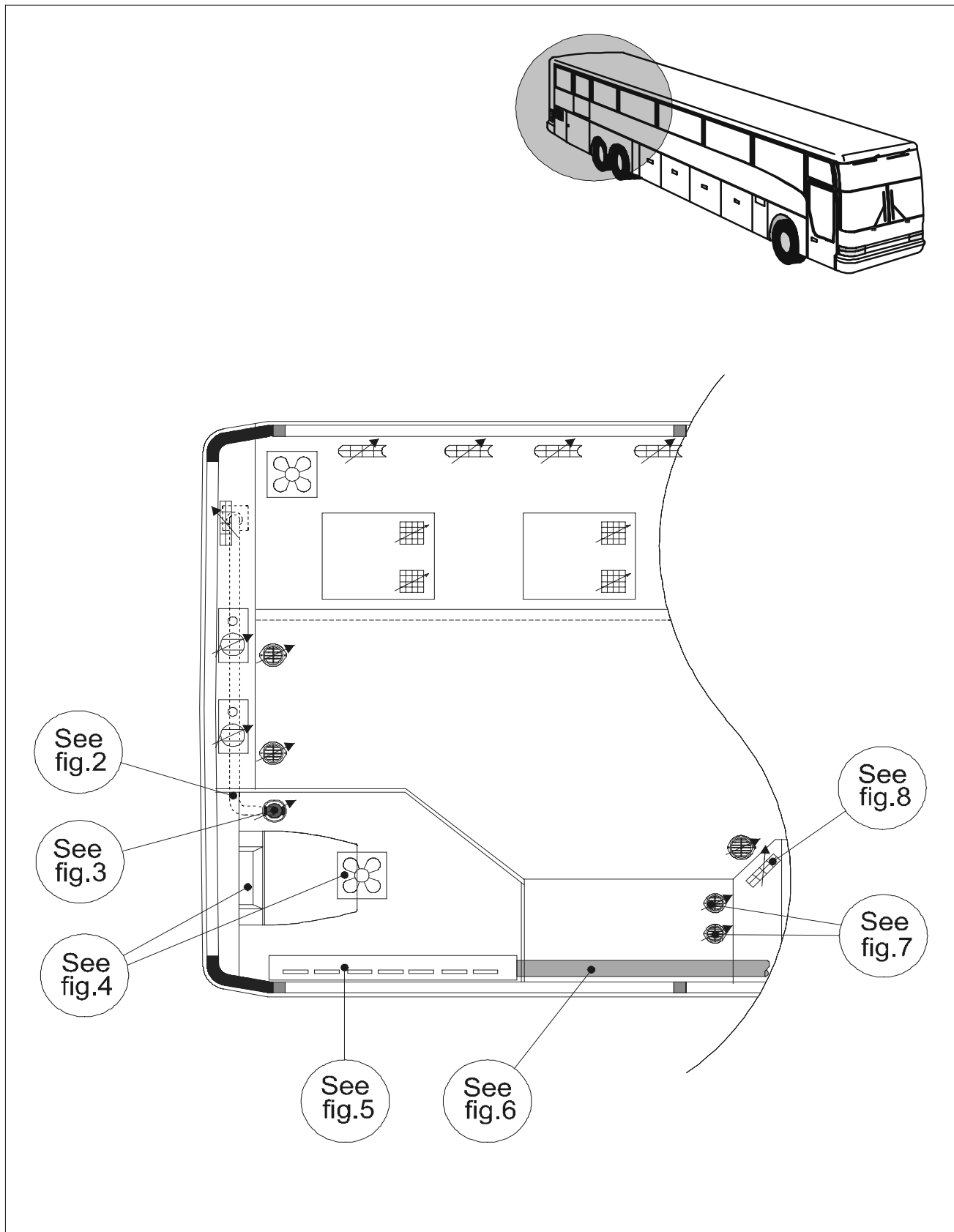

Figure 1: Revised rear quarter ventilation on T2100 Series coaches with ADA lift

Revised ventilation of lift door area and restroom

- To improve ventilation in the rear quarter area, fresh air is taken from the air duct which is hidden by the molding above the rear seats, and which is then supplied to the restroom through a flex tube and an outlet in the restroom ceiling (see Figures 2a, 2b and 3).
- More air is supplied to the restroom through slots in the air outlet molding above the restroom window. This air is taken from the right hand parcel rack duct (see Figures 5, 6a and 6b).
- Used air is removed from the restroom through slots in the trim panel behind the toilet seat (see Figure 4) and evacuated to the outside through a roof mounted extractor fan.
- Additional ventilation in the area next to the rear access door is provided through two additional outlets in the parcel rack bulkhead and one in the parcel rack floor (see Figures 7 and 8).

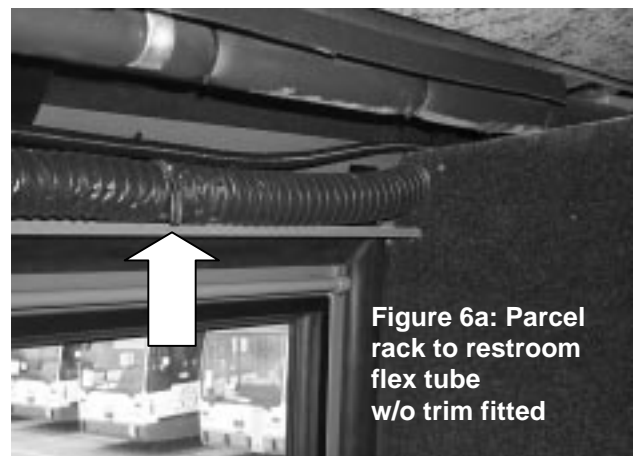
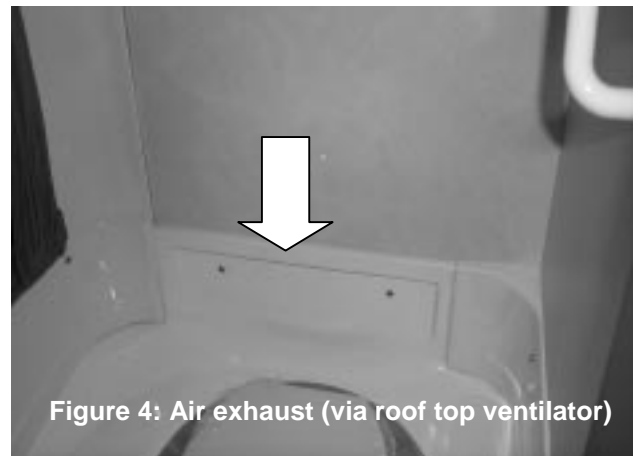
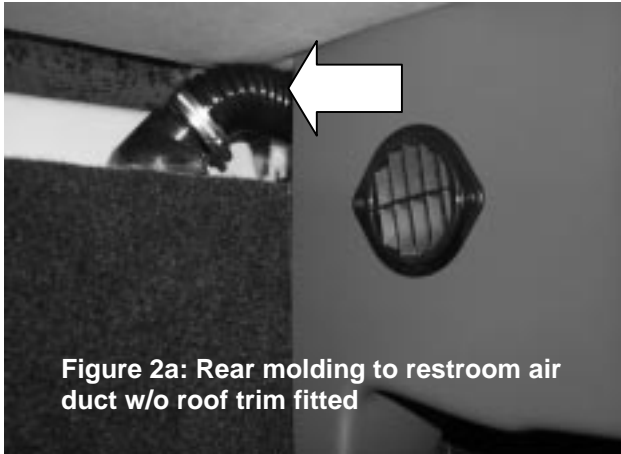



Figure 6b: Parcel rack to restroom flex tube covered by trimmed capping w/ lamp assembly



Figure 7: Additional round air outlets VH 660520405 near rear door



Figure 8: Additional oblong air outlet VH 10627579 near rear door

PARTS AND PRODUCTS:

Part No.	Description	Qty.
VH 660074812	Flex tube, parcel rack to restroom, dia. 2-11/64 inch (55 mm)	3 ft
VH 660074604	Flex tube, rear molding to restroom, dia. 1-49/64 inch (45 mm)	5 ft
VH 209181001	Sleeve, dia. 1-31/32 inch (50mm) for VH 66074812	4 in
VH 660766569	Tie wrap 14-11/64 x 19/64 inch (360 x 7.6 mm)	#
VH 660514502	Hose clamp for VH 66074604, dia 1-31/32 inch (50 mm)	2
VH 660744686	Duct, transition to restroom roof, 45°	1
VH 660520475	Duct, transition to rear molding, 90°	1
VH 660520473	Air outlet, restroom roof, closing, adjustable	1
VH 10833377	Air outlet molding, restroom, slotted w/ diffuser	1
VH 660520405	Air outlet, round, parcel rack bulkhead, non-closing, adjustable	2
VH 10627579	Air outlet, oblong, parcel rack floor, closing, adjustable	1
VH 10572761	Lamp assembly, flex tube trim panel*	1*
VH 10660499	Finishing angle, restroom window top rail, 1x1-3/8x35-53/64 inch	1

*For production units only. This part is not required to retrofit field units.

- Parts may be obtained through regular channels.

- Always use genuine maintenance products and parts. Do not accept imitations.
- Parts and products disposition: discard according to applicable environmental regulations.

PROCEDURE:

1. General:

- The conversion includes 6 stages:

stage 1: installation of additional air outlets in the right hand parcel rack

stage 2: removal of the old air outlet molding above the restroom window

stage 3: rerouting of the lift door service unit flex tube from RH parcel rack to restroom

stage 4: removal and modification of the molding above the rear seats

stage 5: installation of rear molding to restroom roof tubing

stage 6: installation of a new air outlet molding above the restroom window

- For your information only: the time required to retrofit one coach is approximately 5 hours.
- This job should be executed by a technician experienced in bodywork and trim repair.

2. Special tools, equipment or services:

This job requires the use of a:

- 1-5/8 inch hole saw
- 3 inch hole saw
- reciprocating saw
- stapler

3. Preparations:

- Park the coach on a level surface, apply the parking brake and shut down the engine.
- Switch off all systems and turn off the battery master switch.
- Put a “DO NOT OPERATE” tag on the instrument panel.
- Read the entire procedure before beginning to work.

CAUTION: Observe safe shop practices at all times.

Nominal sizes for cutting purposes:

Parcel rack outlet VH 660520405, round: dia 2-59/64 inch (74 mm)

Parcel rack outlet VH 10627579, oblong: 6-17/32 x 1-17/64 inch (166x32 mm)

Flex tube, parcel rack to restroom: dia 2-11/64 inch (55 mm)

Air outlet, restroom roof: dia 3 inch (76 mm)

T-transition to rear molding air duct: dia 1-37/64 inch (40 mm)

Flex tube, rear bench molding to restroom roof: dia 1-49/64 inch (45 mm)

4. To install additional round air outlets VH 660520405 in parcel rack bulkhead: To install additional oblong air outlet VH 10627579 in parcel rack floor next to rear door:

- 1) To install round air outlets VH 660520405, make a template for the two holes in the parcel rack bulkhead (see Figure 7 and nominal size chart), using a piece of suitable cardboard and dividers.

- 2) Referring to the dimensions in Figure 9, position the template on the parcel rack bulkhead and attach with masking tape.
- 3) With a utility knife follow the circumference of the two outlets, at the same time cutting through the template and the fabric. Remove the template and the wasted cloth.
- 4) Secure the fabric remaining around circumference of the holes with a stapler.
- 5) With a suitable hole saw, cut two holes in the plywood to accept the outlets.
- 6) Install the outlets in the holes and secure them with black self-tapping screws.
- 7) Referring to the installation dimensions in Figure 10, proceed likewise for oblong air outlet VH 10627579, cutting the plywood with a reciprocating saw.

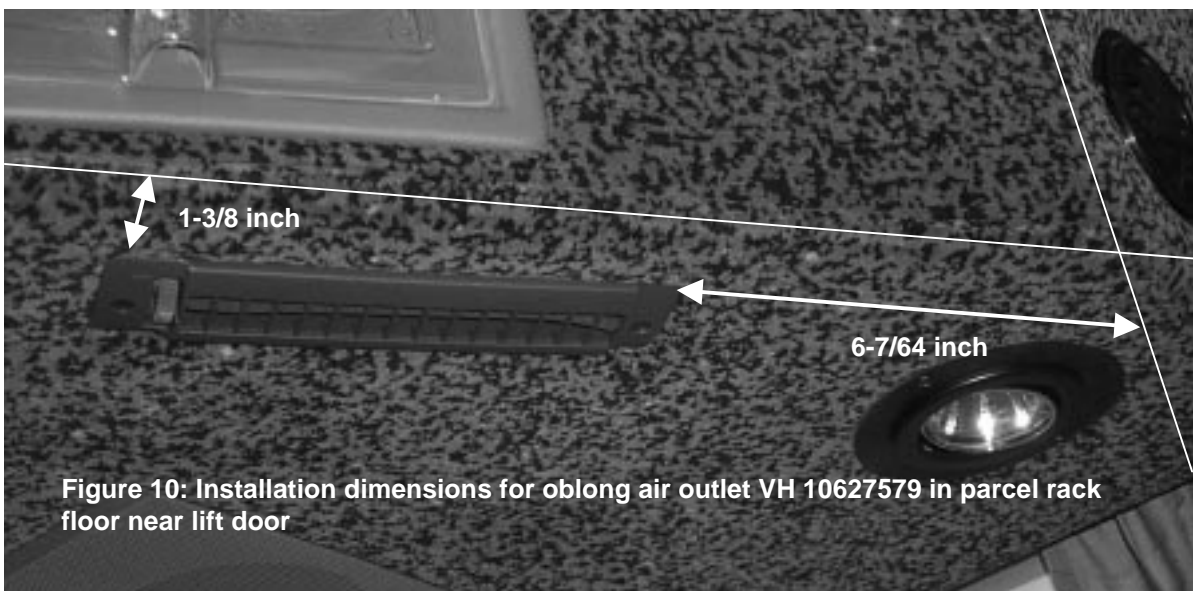
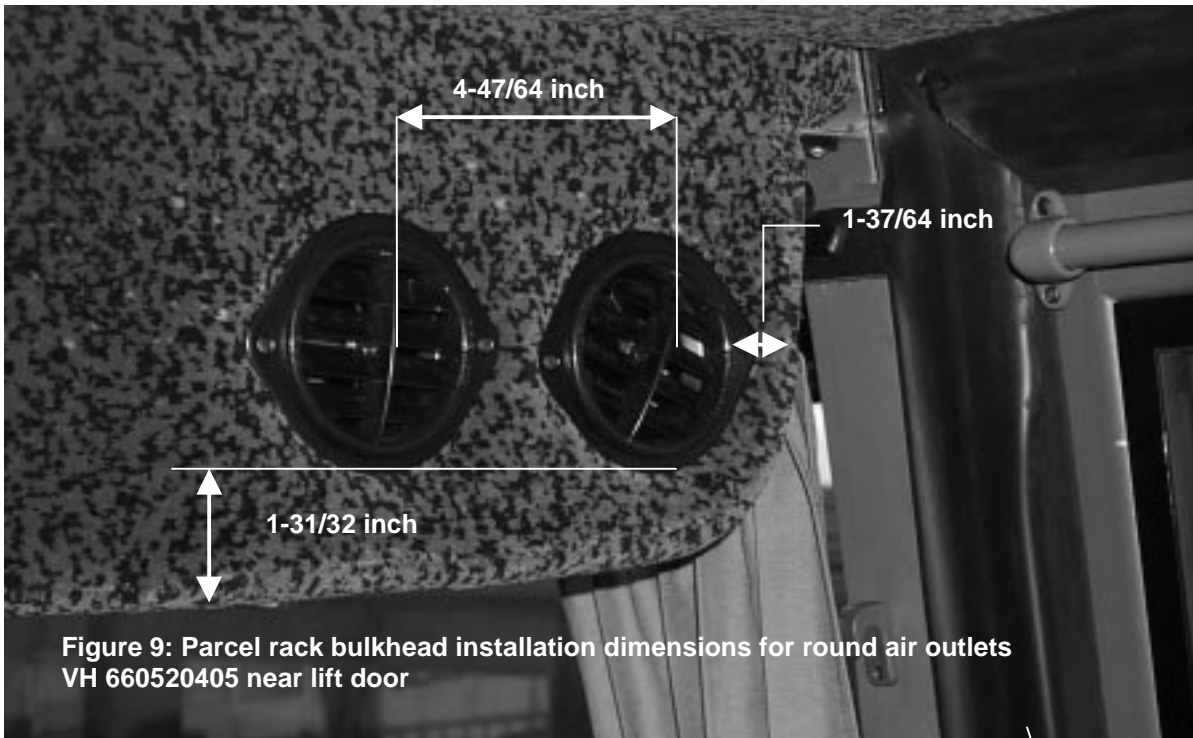

5. To remove the white air outlet molding above the restroom window:

- 1) In the restroom, open the emergency window. Move both curtains towards the middle of the curtain rail. Undo and remove the 4 screws securing the upper curtain rail to the air outlet molding above the window (see Figure 11). Withdraw the rail.

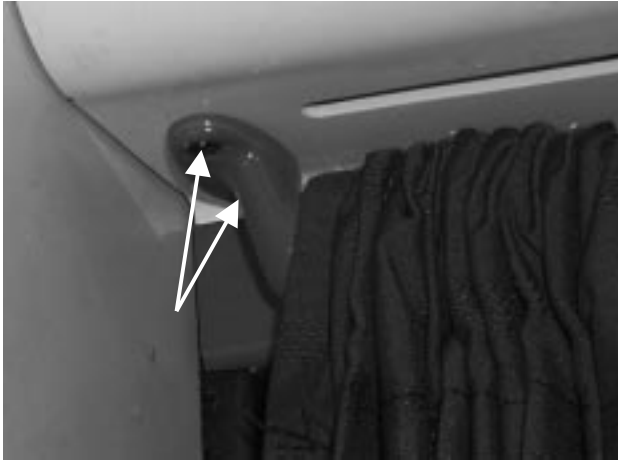

Figure 11: Curtain rail securing screws

- 2) Undo and remove the screws securing the upper corner trim molding (see Figure 12). Withdraw the molding.

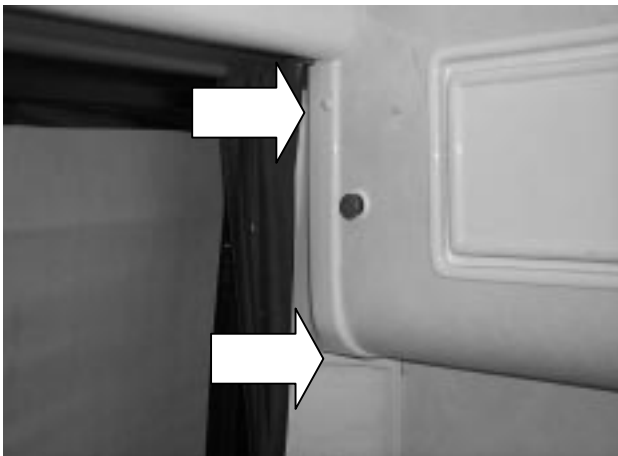

Figure 12: Corner trim molding screws. Note screw head buttons. These need to be removed first.

- 3) Pry loose and discard the finishing angle just below the white molding (see Figure 13).



Figure 13: Finishing angle covering mounting screws and upper window rail

- 4) Undo the screws securing the air outlet molding to the upper window rail. Push and withdraw the molding from the retaining strip on the ceiling (see arrow, Figure 14).



Figure 14: Push the outlet molding towards the window to remove it from the retaining strip.

- 5) Disconnect the courtesy light. Transfer this light to the new molding containing a diffuser.

6. To install parcel rack to restroom tubing:

- 1) Undo and remove the self-tapping screws securing the lift door overhead capping to the coach body. See Figure 15 for the approximate location of the screws, which are hidden in the fabric. Lower the capping.

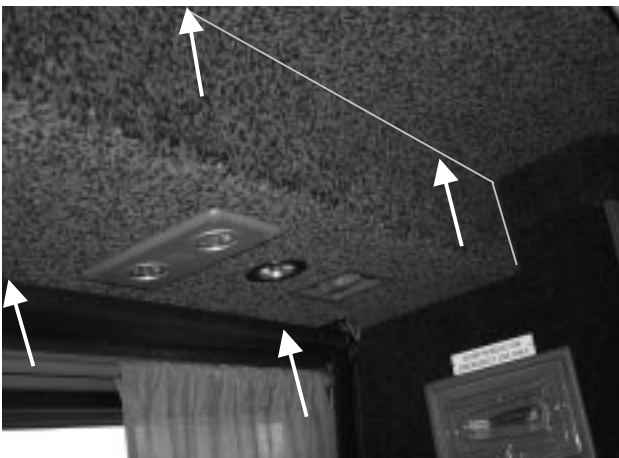

Figure 15: Lift door overhead capping. Approximate location of screws.

- 2) Separate the flex tube from the service module. Mark and disconnect the service module wiring and the lift door emergency release valve pneumatics. Remove the capping.
- 3) Cut a piece of rigid plastic tubing VH 209181001 (size: 1-31/32 inch diameter by 4 inches long) to serve as a sleeve. Insert half of the sleeve in the flex tube formerly attached to the service module. Secure with a tie wrap.
- 4) Cut a suitable length (approximately 3 ft) of 2-11/64 diameter flex tubing VH 660074812 to be connected to the new molding/diffuser, which will be installed in the restroom later in the procedure. Connect one end of this tubing to the sleeve and secure with a tie wrap. Insert the other end through the top opening of the restroom wall making sure the tubing sticks about 1 foot into the room. If no hole is present, make one as per procedure in item 4 of this Bulletin. Secure flex tubing with tie wraps (see Figure 16).

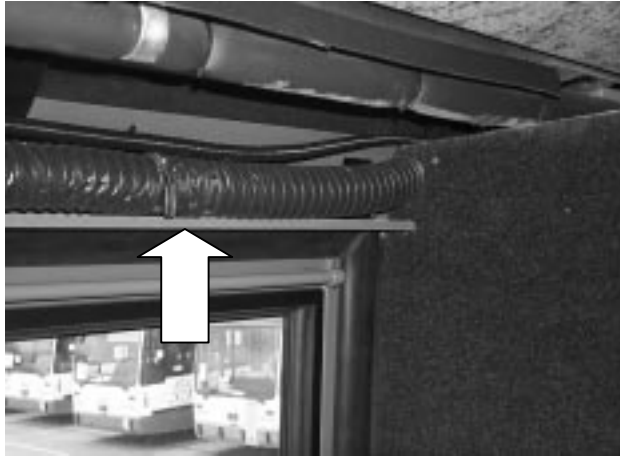

Figure 16: Parcel rack to restroom flex tubing installation

- 5) Reconnect the service module wiring and the lift door emergency release valve pneumatics. Reinstall the overhead capping.

7. To remove and modify the molding above the rear seats:

- 1) Inside the recess between the two rear bench reading lights, undo and remove the self-tapping screws securing the rectangular cover plate. Remove the plate.
- 2) Undo and remove the retaining screws of the two rear passenger reading lights/air vents. Pull the light/vent units from the molding and disconnect the terminals.
- 3) Remove the rearmost service module from the left hand parcel rack by withdrawing the six retaining screws (see Figure 17).

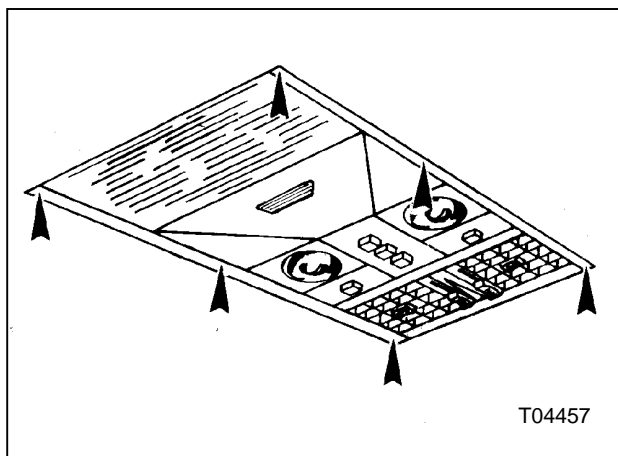

Figure 17: Service module. Location of screws. Remove screw head buttons first

- 4) Mark and disconnect the service module terminals.
- 5) Remove the rearmost left hand curtain by pulling the curtain retaining spring from the eyelet screws.
- 6) Optional: remove the small L-shaped molding end plate between the rearmost passenger window and the parcel rack.
- 7) Using a long cross tip screwdriver undo and remove the retaining screw(s) on the inside of the molding through the opening between the two reading light bowls (1, Figure 18). Undo and remove the retaining screws at the back of the molding (2, Figure 18).

Through the service module opening in the parcel rack, undo the retaining screws at the front of the molding (3, Figure 18). Withdraw the molding by pulling it down.

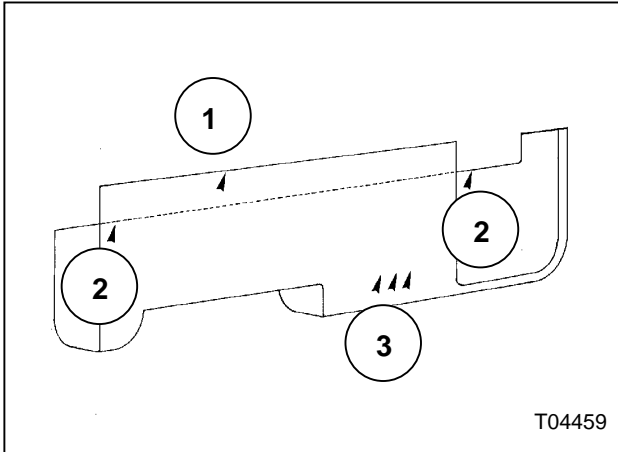

Figure 18: Rear bench ABS molding.
Approximate location of retaining screws

- 8) Install the T-shaped transition duct referring to the dimensions in Figure 19. Start by drilling a 1-5/8 inch hole in the molding duct. Center the hole in the transition duct with the hole in the molding. Secure with Sikaflex 221 or a similar adhesive, rivets at the four corners, and back-up washers.

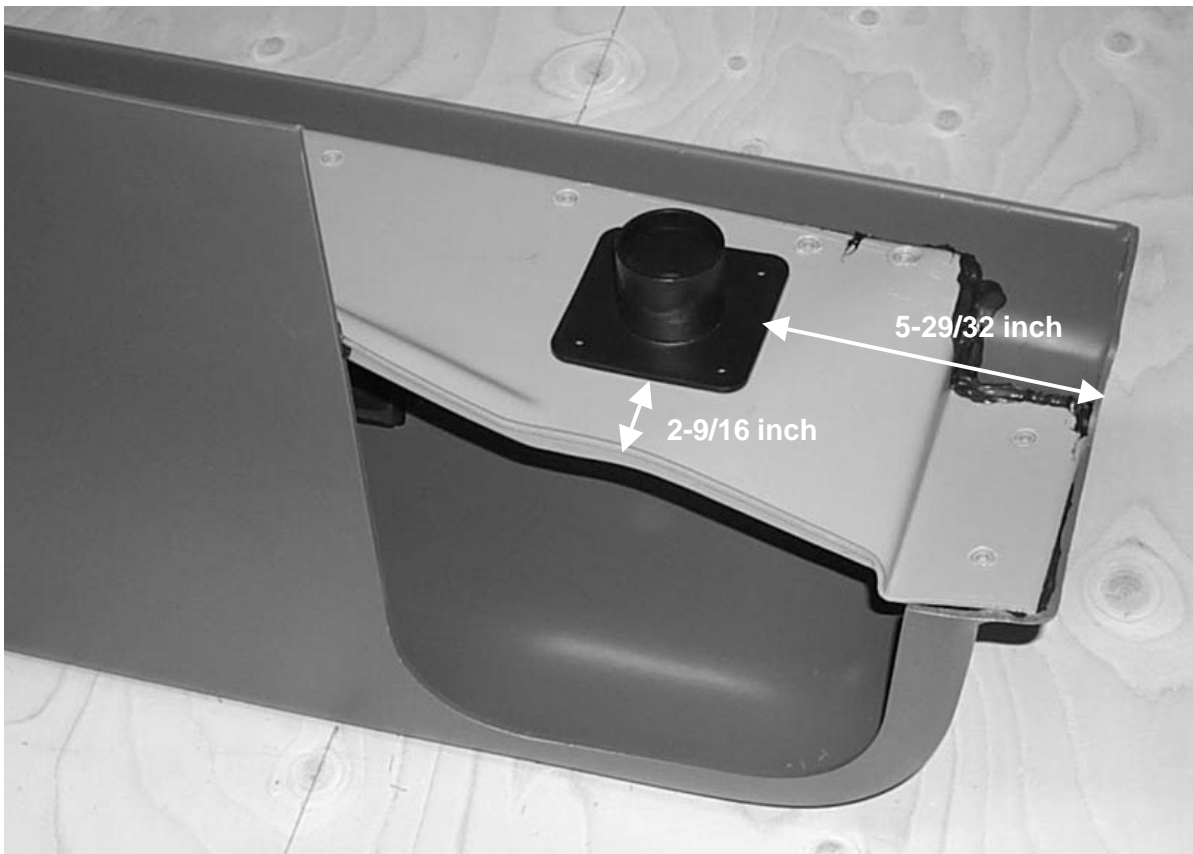

Figure 19: Location of transition duct on rear molding duct

8. To install rear molding to restroom roof tubing:

- 1) On the outside of the restroom, adjacent to the coach' roof, is a trimmed plinth. Insert a flat screwdriver beneath it (see Figure 20) and carefully pry it loose.

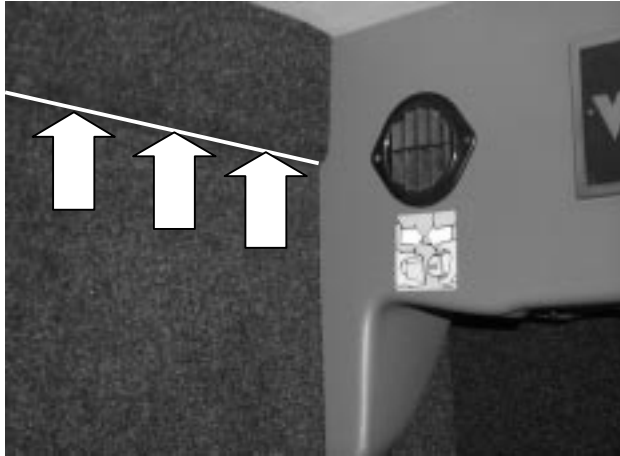

Figure 20: Trimmed plinth covering the gap between restroom ceiling and coach roof

- 2) In the restroom, cover the area where the air outlet will be installed with masking tape (see Figure 21). Cut a hole through the tape and the ceiling using a 3-inch hole saw. Remove the tape once the hole is finished.

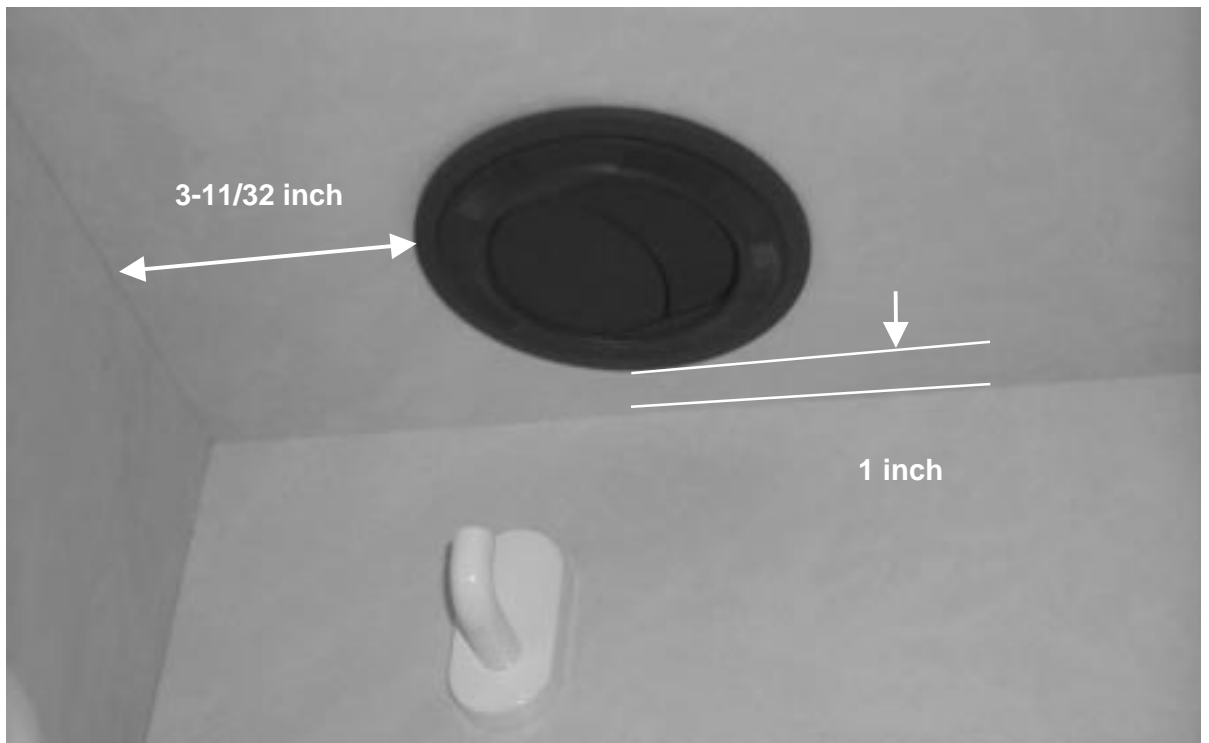

Figure 21: Installation dimensions for air outlet in restroom roof

- 3) Assemble transition duct VH660744686 and air outlet VH 660520473 by simply inserting one into the other and pressing both parts together.
- 4) Attach 5 feet of 1-49/64 diameter flex tube VH 660074604 to the transition part of the new assembly. Secure with a 1-3/4 inch + hose clamp.
- 5) Insert the flex tube and assembly through the hole in the ceiling, making sure the transition part of the assembly points towards the rear of the coach. Push the assembly fully home. This installation is press-fit (see Figure 22).

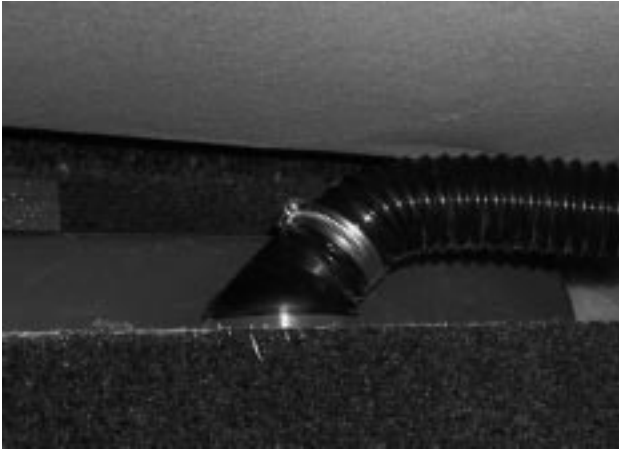

Figure 22: Air outlet/transition duct assembly and flex tube installation

- 6) Run the tubing over the restroom roof and reinstall the molding in reverse order to removal.
- 7) Reinstall the service module in reverse order to removal.
- 8) Reinstall the rear passenger reading lights/air vents in reverse order to removal.
- 9) Reinstall the cover plate in the recess between the two rear bench reading lights.
- 10) Reinstall the trimmed plinth by tapping it on the headless nails in the restroom wall.

9. To install slotted restroom air outlet molding with diffuser VH 10833377:

- 1) Attach the flex tubing coming from the parcel rack to the T- transition duct of the diffuser (see Figure 23). Secure with a hose clamp.

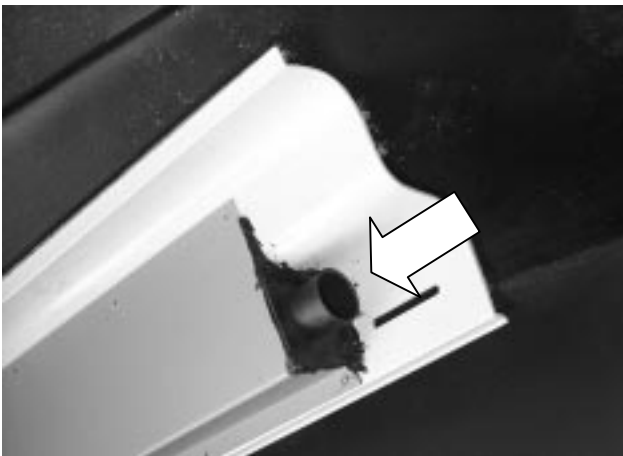

Figure 23: Air outlet molding with built-in diffuser. Note T-transition.

- 2) Connect the courtesy light.
- 3) Install the new air outlet molding in reverse order to removal of the old one.
- 4) Install a new finishing angle on the upper window channel using two-sided sticky tape.
- 5) Reinstall the upper corner trim molding. Install the screw head buttons.
- 6) Reinstall the curtain rail and curtains.

Procedure complete.

SERVICE INFORMATION:

Service Bulletins are issued to supplement or supersede information in the Van Hool manuals. Note Service Bulletin number, date and subject on the register at the end of the relevant chapter(s). File Service Bulletin separately for future reference.

WARRANTY INFORMATION:

- Causal part: VH 4830118
- Job code: E50519N
- Parts disposition: discard according to applicable environmental regulations.

Van Hool will accept warranty claims for this repair as follows:

- Parts: Parts may be obtained from your nearest ABC Customer Care and Parts Source dealership.
- Labor allocation for this conversion: 5 hours.
- Expiration date: Service Bulletin issue date + 1 year.

Contact ABC Customer Care & Parts Source for guidance on claim submission.

THIS PAGE HAS BEEN LEFT BLANK INTENTIONALLY