



# SERVICE BULLETIN

SB1242

|                               |  |
|-------------------------------|--|
| <b>ADDRESSEES</b>             | : ABC Customer Care and Parts Source<br>Owners and operators of coaches listed under 'Application' |
| <b>VEHICLE MODEL</b>          | : C2045 New Look   |
| <b>SYSTEM/SUBSYSTEM</b>       | : Body and body accessories – Maintenance doors  |
| <b>BULLETIN TYPE</b>          | : Product Improvement  |
| <b>DATE</b>                   | : May 9, 2011  |
| <b>SUBJECT</b>                | : <b>Evaporator door retention</b>   |
| <b>TERMS &amp; CONDITIONS</b> | : Note that no reimbursement will be awarded for carrying out this product improvement.            |

## **APPLICATION:**

C2045 coaches equipped with new-style evaporator door assemblies #11000183 (right-hand) and #11000178 (left-hand, Figure 1).



## **DESCRIPTION:**

1. Service records have shown that on the above-mentioned units evaporator door retention issues may be encountered.
2. To address these issues, a product improvement has been developed, which entails the installation of new, unidirectional door latches and differently shaped retaining angles.
3. This Product Improvement Bulletin has been released to inform customers of the new developments.  
Therefore, should evaporator door retention issues be encountered on your vehicle, you may refer to the materials list and apply the step-by-step instructions from the procedure.

**MATERIAL:**

**Old**

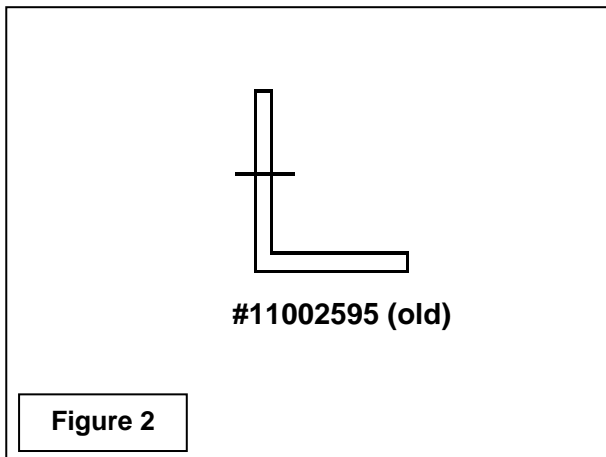

| VH reference | Description                                | Qty. | Refer to |
|--------------|--|------|----------|
| 11002595     | Angle, evaporator door retaining, aluminum | 2    | Figure 2 |
| 11080756     | Latch, bi-directional                      | 6    | Figure 3 |

**New**

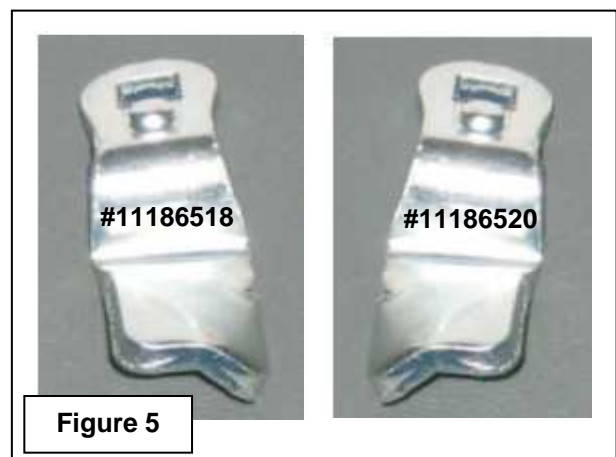
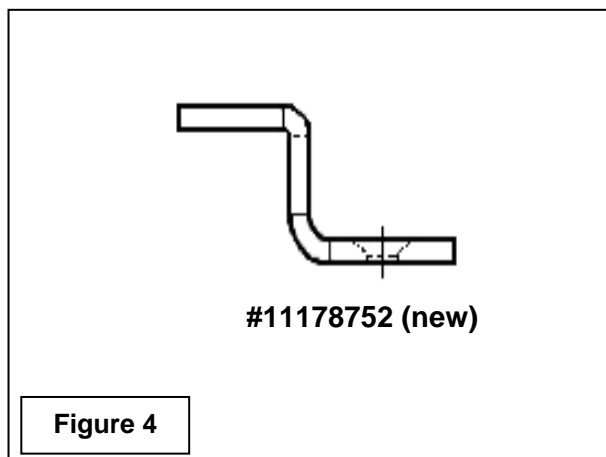

| VH reference | Description                      | Qty. | Refer to |
|--------------|----------------------------------|------|----------|
| 11178752     | Strip, Z-shaped, stainless steel | 2    | Figure 4 |
| 11186518     | Latch, left-hand                 | 5    | Figure 5 |
| 11186520     | Latch, right-hand                | 1    | Figure 5 |

- Old and new parts are interchangeable but only the new will be offered as service replacements.
- Material may be purchased through regular channels.
- Parts/Waste disposal: discard old material according to applicable environmental regulations.

*Continued on next page.*

**PROCEDURE: To replace the evaporator door retaining angle and latches**

**1. General:**

- This job has to be carried out by a technician proficient in body and trim repair.
- For more information refer to the service literature that comes with the vehicle.
- If you do not have the expertise to carry out present procedure, do not hesitate to go to your nearest ABC Customer Care & Parts Source service center.

**2. Special tools, equipment or services:**

- This job does not require special tools, equipment nor services.

**3. Preparations:**

- Park the coach safely, apply the parking brake, stop the engine, switch off all systems and turn off the battery master switch.
- Read the entire procedure before beginning to work.
- Observe safe shop practices at all times.

**4. To replace retaining angles #11002595:**

- 1) Unlock and lower the door covering the left-hand evaporator module (Figures 6a and 6b). Detach the door from the check straps (Figure 6c). Lift the door off the parcel rack handrail and store it out of the way.

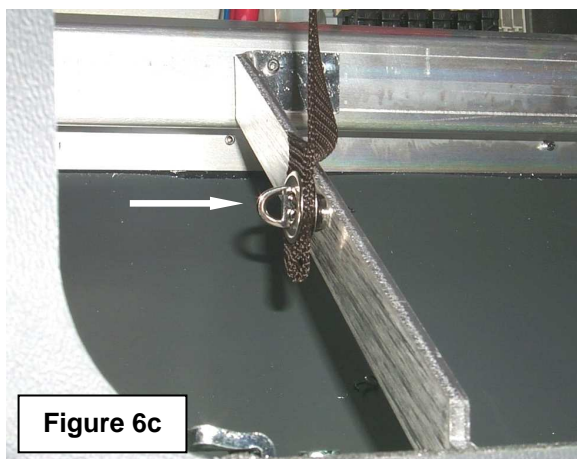

- 2) Angle #11002595 (Figure 7a) has been attached to the roof frame by five screws. Undo and remove the screws securing the check straps on either side of the angle (Figure 7b). Recover the check straps and fasteners. Undo, remove and recover the remaining fasteners. Remove and discard the angle.

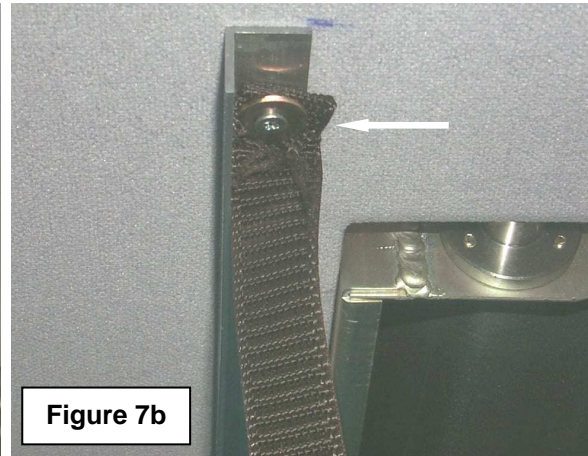
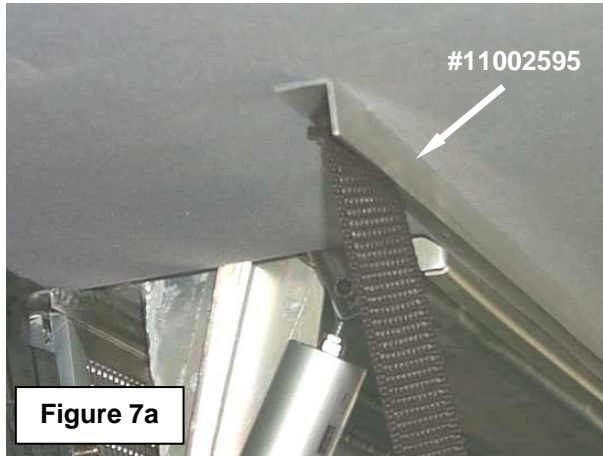

- 3) Using the existing screw holes in the roof frame as a reference, install z-shaped strip #11178752 with the recovered fasteners as shown in Figure 8. Install the recovered check straps. Secure all fasteners hand tight.



- 4) Repeat steps 1 through 3 for the right-hand evaporator module.

## 5. To replace evaporator door latches #11080756:

*NOTE: Old latches are bi-directional (Figure 3) with shallow curvature. New latches are directional with pronounced curvature to one side. Refer to Figure 9 for the location on the evaporator doors of new latches #11186518 and #11186520.*

*Continued on next page.*

**Evaporator door assembly #11000183  
in right-hand parcel rack C2045 new look**

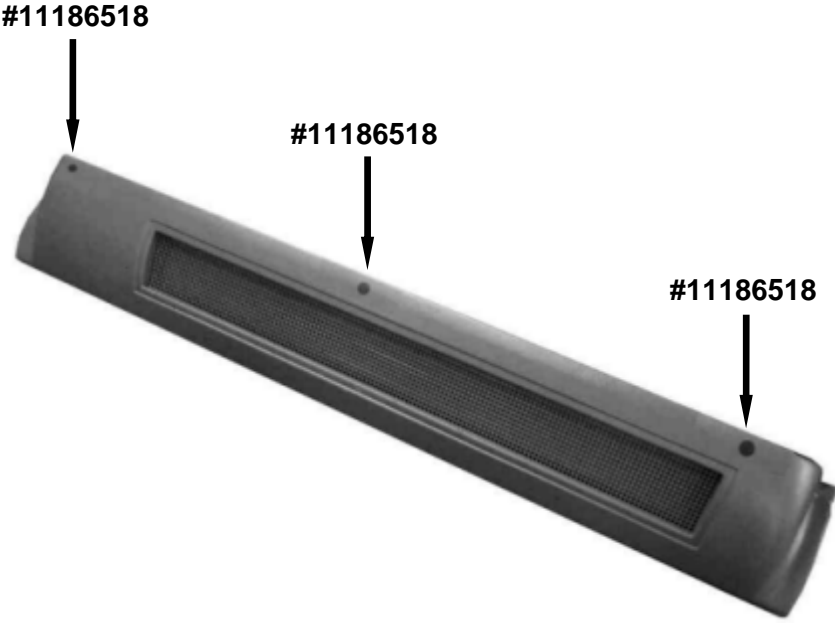

**Evaporator door assembly #11000178  
in left-hand parcel rack C2045 new look**



**Figure 9**

- 1) Replace the door latches one by one.  
On the inside of the door, undo and remove the center bolt securing the latch to the square drive (Figure 10).  
Detach and discard the old latch.

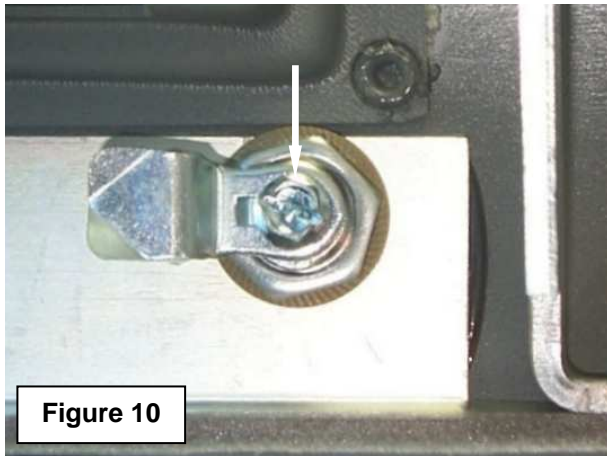

- 2) Refer to Figure 9 to determine the replacement latch required for the location.  
Install the new latch in reverse order to the removal of the old one.  
Secure the center bolt hand tight.
- 3) Reinstall the evaporator doors in reverse order to removal.

*Procedure complete.*

### **DISCLAIMER:**

The procedures contained herein are not exclusive. Van Hool cannot possibly know, evaluate, or advise the transportation industry of all conceivable ways in which a procedure may be undertaken or of the possible consequences of each such procedure. Other procedures may be as good, or better, depending upon the particular circumstances involved.

Each carrier who uses the procedures herein must first satisfy itself thoroughly that neither the safety of its employees or agents, nor the safety or usefulness of any products, will be jeopardized by any procedure selected.

### **INFORMATION HANDLING:**

Important supplements to and modifications of the technical information not yet included in the Van Hool manuals are communicated by means of Service Bulletins.

File the Service Bulletins at the back of your manual, in numerical order.

To make sure that you will be reminded of the Bulletins that have appeared in the meantime while paging the manual, mark the pages concerned by hand with the Service Bulletin number.