



SERVICE BULLETIN

SB1250

ADDRESSEES	: ABC Customer Care and Parts Source (Other) Owners and operators of coaches listed under 'Application'
SYSTEM	: Rear Axle Chassis Reinforcement
COMPONENT	: Drive Axle Area
BULLETIN TYPE	: Field Change Service Bulletin
DATE	: March 17th, 2016
SUBJECT	: To Reinforce the TD 925 Chassis in the Drive Axle Area
TERMS & CONDITIONS	: This document is subject to warranty Claims : Refer to the warranty section further in this Bulletin.

APPLICATION:

Model	VIN
TD 925 US	VINS 42301 -> 42604 (LHS + RHS) VINS 42605 -> 42629 (RHS only) VINS 42648 -> 42665 (RHS only)

DESCRIPTION:

PLEASE READ THE ENTIRE BULLETIN BEFORE BEGINNING ANY REPAIRS

1. This procedure has been released to owners of affected Van Hool TD925 coaches in order to reinforce and repair frame cracks if they exist on the cross members in the drive axle areas.
2. Affected VIN numbers are included on the first page of this bulletin. Please refer to the following instructions and parts list outlining corrective action and repairs.
3. The parts information on page 2, 6, 7, 8, 9, 10, 11, 12, 13, 15, 16, 17, 18, 19 and 20 of this procedure should be copied and inserted in the relevant section of the coach Owner's/Operator's Spare Parts Manual.

Please refer to the materials list and apply the step-by-step instructions from the procedure. For your information, the Product Improvement subject of this service document has been cut into production as from VIN 42605 for LHS reinforcement respectively VIN 42648 for RHS reinforcement.

PARTS AND PRODUCTS:

Retrofit parts:

- **The complete set contains two separate kits: 1 LHS set and 1 RHS set for all units and contains the following parts:**

		LHS of Vehicle	RHS of vehicle
Front of rear axle		Set: 11322363	Set: 11356204
	Front side	11322308 + 11322498	11356206 + 11322498
	Backside	11322309	11356207
Behind rear axle		Set: 11322578	Set: 11356214
	Front side	11322499 + 11322498	11322499 + 11322498
	Backside	11322501	11356215
Air line clamp adaptor		10603602	10603602

- All reinforcement parts (LHS and RHS) are made of mild steel; apply the correct welding procedure.

PROCEDURE:

1. General:

- This job should be executed by an experienced welder.
- For more information refer to:
 - Maintenance Manual
 - Spare Parts Manual
 - Operating Manual

2. Special tools, equipment or services:

- This job requires the use of MIG welding equipment, a 3" cutter, and an angle grinder.

3. Preparations:

- Park the coach on a level-surfaced service pit.
 - If portable post lifts are going to be used, lower the suspension first.
- Apply the parking brake and shut down the engine.
- Switch off all systems and turn off the battery master switch.
- Put a "DO NOT OPERATE" tag on the instrument panel.
- Remove necessary tires and wheels to gain access to affected areas.

CAUTION: Observe safe shop practices at all times.

4. Shop practice and safety rules

Welding data:

Table 1: Welding data for mild steel to mild steel
Welding data according to AWS A 5.18 ER 70S-6
• Welding wire section: 1.0 mm (0.039 inch)
• Welding wire feed speed: 2.9-8.4 m/min (115-330 inch/min)
• Current: 80-190 Amps
• Welding gas: 75% Argon + 25% CO ₂ (option: 80% Argon + 20% CO ₂)

NOTE: Welding gas with a high Helium content introduces a lot of heat in the welding area leading to a harder and more brittle weld.

Welding safety rules:

- The following information pertaining to welding should be read before beginning any such procedure. The prohibitions and requirements contained herein must be followed during such procedure.
- **Welding must be done only by a qualified and experienced person.**
 - It is the responsibility of the welder to make sure that his/her personal safety equipment and the welding equipment he/she is using are in a condition that the welding equipment he/she is using are in a condition that will not endanger his/her health and safety or the health and safety of others.
- Adequate ground contact and barriers must be positioned as required to protect components (wiring, air-lines, hydraulic lines, fuel lines etc.) from damage due to heat, contact by weld spatter, arcing or other potentially damaging events associated with welding.
- The following precautions must be taken to protect the vehicle's electronic equipment:
 - FIRST disconnect the wires from the GND (ground) terminal of the battery equalizer.
 - Disconnect the batteries (disconnect ground cable first, reconnect ground cable last).
 - Disconnect the engine, transmission and brake system ECU's.
 - Disconnect the HVAC and combustion heater ECU's.
 - Disconnect the MUX nodes.
 - On shell units, also disconnect the suspension ECU if the vehicle is equipped with an electronic control unit.
 - For any other electronic equipment (radio, video, ICE...) refer to the OEM prescriptions.
 - Keep the ground clamp as close as possible to the work and make sure the clamp makes perfect contact with the drive axle housing.
 - Make certain the welder is properly grounded will not endanger his/her health and safety or the health and safety of others.
 - Never look at the arc unless wearing a suitable helmet or face shield.
 - Wear protective clothing and gloves.
 - Do not permit bystanders, unless they are wearing protective gear.
 - Never weld while standing in water or on damp ground.
 - Have adequate ventilation.
 - Do not adjust machine settings while the machine is under load.
 - Keep cables tight in the sockets.
 - Do not touch hot metal.
 - Do not allow the welding rod/wire to touch anything but the work.
 - Make sure there is nothing flammable near the working area.
Always have a fire extinguisher of the correct type available.

Grinding safety rules:

- Grinders can be dangerous. When improperly used, they are responsible for many serious and lasting injuries to the eyes, hands, face and body. Therefore you must always observe the following safety rules:
 - Always wear eye protection (safety goggles, face shield). Wear leather gloves.
 - Adequate barriers must be positioned as required to protect components (glass, wiring, airlines, hydraulic lines, fuel lines, drive shaft etc.) from damage by grinding sparks.
 - Before doing any grinding on the coach, thoroughly clean the affected area.
 - Keep abrasive discs tight, clean and true.
 - Allow grinder to reach full rpm before using.
 - Do not put aside the grinder until the wheel has completely stopped revolving.
 - Never strike a grinding wheel while revolving. It may shatter and explode.
 - Do not grind in the presence of explosive vapors (gasoline, paint thinner, batteries...)
 - Before installing a new grinding disc, disconnect the electric mains or air supply line.
 - When installing a new disc make certain:
 - It is designed for the rpm of the grinder.
 - It has the correct size.
 - It is properly fixed.
 - Never remove the grinding disc guard.

Aftertreatment :

- Coat the reinforcing parts and bare metal with primer + undercoating allow to dry.

5. To check chassis members for cracks, and to repair possible damage:

- 1) Underneath the coach, in the drive axle area, on both sides of the vehicle, locate the chassis members.
- 2) Refer to the grinding safety rules.
Using an angle grinder remove all undercoating and paint from and around the joints as shown in Figure 1.
Make sure that enough bare metal is exposed to allow detection of possible cracks.
At the same time provide a proper surface for welding on the reinforcing parts.



Figure 1

- Clean welding area thoroughly
- Drill a hole at the end of the crack

- 3) If a crack is detected, drill a 5/32-inch (4 mm) diameter hole at each end of the crack to stop it from progressing any further.
- 4) With a 3-inch cutter cut through the crack along its entire length.
- 5) Refer to the welding data and the welding safety rules.
Seam weld the crack.
Dress the weld with a grinder.
- 6) Repeat steps 2 through 5 for all joints showing cracks.
- 7) The reinforcement plates are welded to the chassis with a STRIP weld as indicated on figure 2. The plate number is indicated on the figures and the length of the strips as well.

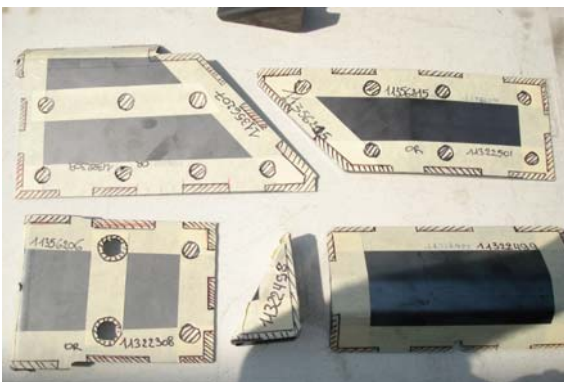

Figure 2

- Make sure that enough bare metal is exposed to allow detection of possible cracks.
- At the same time provide a proper surface for welding on the reinforcing parts

NOTE: further details: see drawings enclosed – pages 14 to 20

8) Plug welding as indicated on figure 3

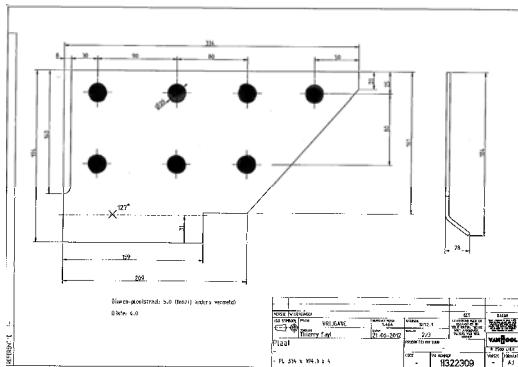

Figure 3

9) If there is an “air line clamp adaptor” welded in the position where the reinforcement plates will be installed, the adaptor has to be removed and afterwards a new one needs to be installed in the same position. Welding the adaptor in a different position can lead to bent air lines.

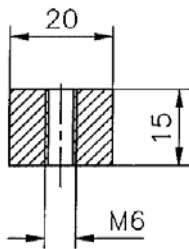

Figure 4: Air line clamp adaptor(x)

- **VH number:** 10603602

6. Position of the reinforcement plates

As mentioned in table 1 on page 2 of this bulletin, the complete set consists of a left hand set and a right hand set.

LHS set consists of:

- Front of rear axle (Set VH 11322363)
Front side (VH 11322308 + 11322498)
Back side (VH 11322309)
- Behind rear axle (Set VH 11322578)
Front side (VH 11322499 + 11322498)
Back side (VH 11322501)
- 1x Air line clamp adaptor (VH 10603602) (supplied by ABC)

RHS set consists of:

- Front of rear axle (Set VH 11356.204)
Front side (VH 11356206 + 11322498)
Back side (VH 11356207)
- Behind rear axle (Set VH 11356214)
Front side (VH 11322499 + 11322498)
Back side (VH 11356215)
- 1x Air line clamp adaptor (VH 10603602) (supplied by ABC)

6.1 - Left hand side set: front of rear axle (set VH 11322363)



Figure 5: LHS Reinforcement

- Reinforcement of the drive axle left front air bellow support
- Cover the air bellow while welding to avoid damage due to melted material



Accessibility

Figure 6, 7 and 8: Front side view

- **VH 11322308; 11322498**
- Access through panel in bus lavatory.
- After welding: make sure this panel is well closed again to avoid noise and dust penetration.





Figure 9: Back side view

- **VH 11322309; 11322498**
- Protect air bellow
- Reweld air line clamp adaptor

6.2 - Left hand side kit: behind the rear axle (set VH11322578)



Figure 10: LHS reinforcement

- Reinforcement of drive axle
- left rear air bellow support
- Protect air bellow, air lines and leveling valve while welding



Figure 11: Front side view

- **VH 11322499 and 11322498**
- Reinforcement of the shock absorber bracket and the air bellow bracket.



Figure 12: Back side view

- **VH 11322501**
- Protect air bellow, air lines and leveling valve while welding

6.3 – Right hand side kit: Front of rear axle (set VH 11356204)



Figure 13: (LHS)

- Accessibility through panel at second step.

Figure 14: (RHS)

- **VH 11356206**
- Front of rear axle
- Protect air bellow and air line while welding



Figure 15 and 16: Back side view

- **VH 11356207**
- Reinforcement of longitudinal beam
- Protect air bellow, air lines and bushing of anti-roll bar while welding



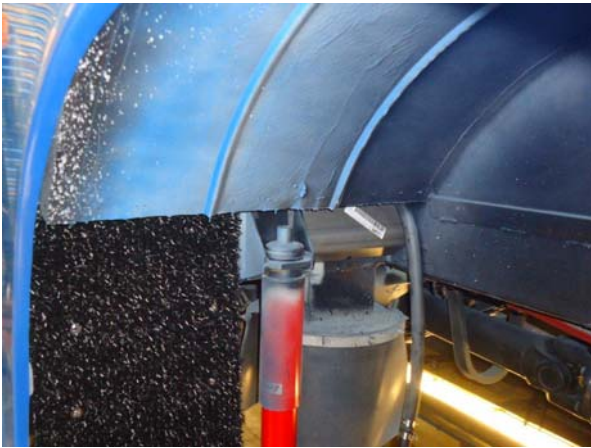

Figure 17 and 18: Front side view

- **VH 11322499 and 11322498**
- Reinforcement of shock absorber and air bellows bracket
- Protect air bellow, air lines and bushing of anti-roll bar while welding

6.4 – Right hand side kit: behind the rear axle (set VH 11356214)

Front side (VH 11322499 + 11322498) : See figure 9

Back side (VH 11356215)



Figure 19: Back side view

- **VH 11356215**
- Reinforcement of longitudinal beam and air bellow bracket.
- Protect air bellow and air lines while welding

DISCLAIMER:

The procedures contained herein are not exclusive. Van Hool cannot possibly know, evaluate, or advise the transportation industry of all conceivable ways in which a procedure may be undertaken or of the possible consequences of each such procedure. Other procedures may be as good, or better, depending upon the particular circumstances involved.

Each carrier who uses the procedures herein must first satisfy itself thoroughly that neither the safety of its employees or agents, nor the safety or usefulness of any products, will be jeopardized by any procedure selected.

INFORMATION HANDLING:

Important supplements to and modifications of the technical information not yet included in the Van Hool manuals are communicated by means of Service Bulletins.

File the Service Bulletins at the back of your manual, in numerical order.

To make sure that you will be reminded of the Bulletins that have appeared in the meantime while paging the manual, mark the pages concerned by hand with the Service Bulletin number.

WARRANTY:

1. Terms and conditions:

CAUTION: Owners are required to inform ABC CUSTOMER CARE , as per Form VH – 2013 - 02 attached to this Bulletin that the retrofit has been carried out in accordance with the manufacturer's instructions.

Van Hool NV/ABC Bus Inc. will accept warranty claims for this repair as follows:

Parts:

- Supply: parts will be supplied through ABC Customer Care and Parts Source, free of charge.
- Return: none.
Disposal: discard parts according to applicable environmental regulations.

Labor allowance: 14-18 hours of labor will be awarded per coach repaired.

Campaign expiration/target date: Service Bulletin issue date + 1 year

2. Claim References:

- Causal part:
 - **RHS: 11356204 (+11356214)**
 - **LHS: 11322363 (+11322578)**
- Job code: **D10108H**

Claim submission: If there are any questions regarding this campaign, please call ABC Customer Care & Parts Source toll-free for guidance at 1-877-427-7278. Listen for the prompts for warranty and select that option.

3. Monitoring and performance:

The claim records pertaining to this Bulletin will be used to determine that the remedy has been executed in accordance with the manufacturer's instructions.

Drawings – Enclosures to Figure 2

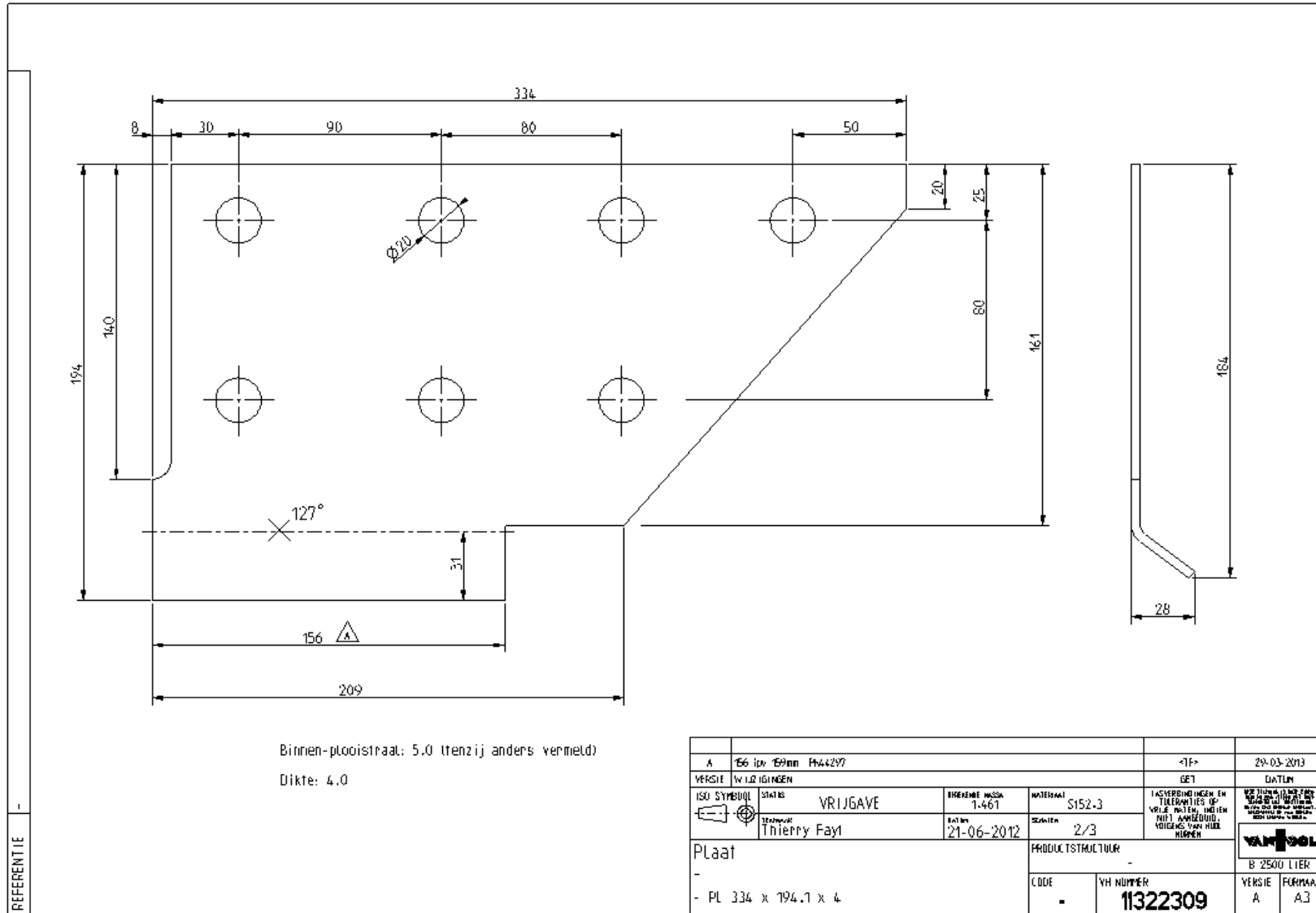

REFERENTIE -

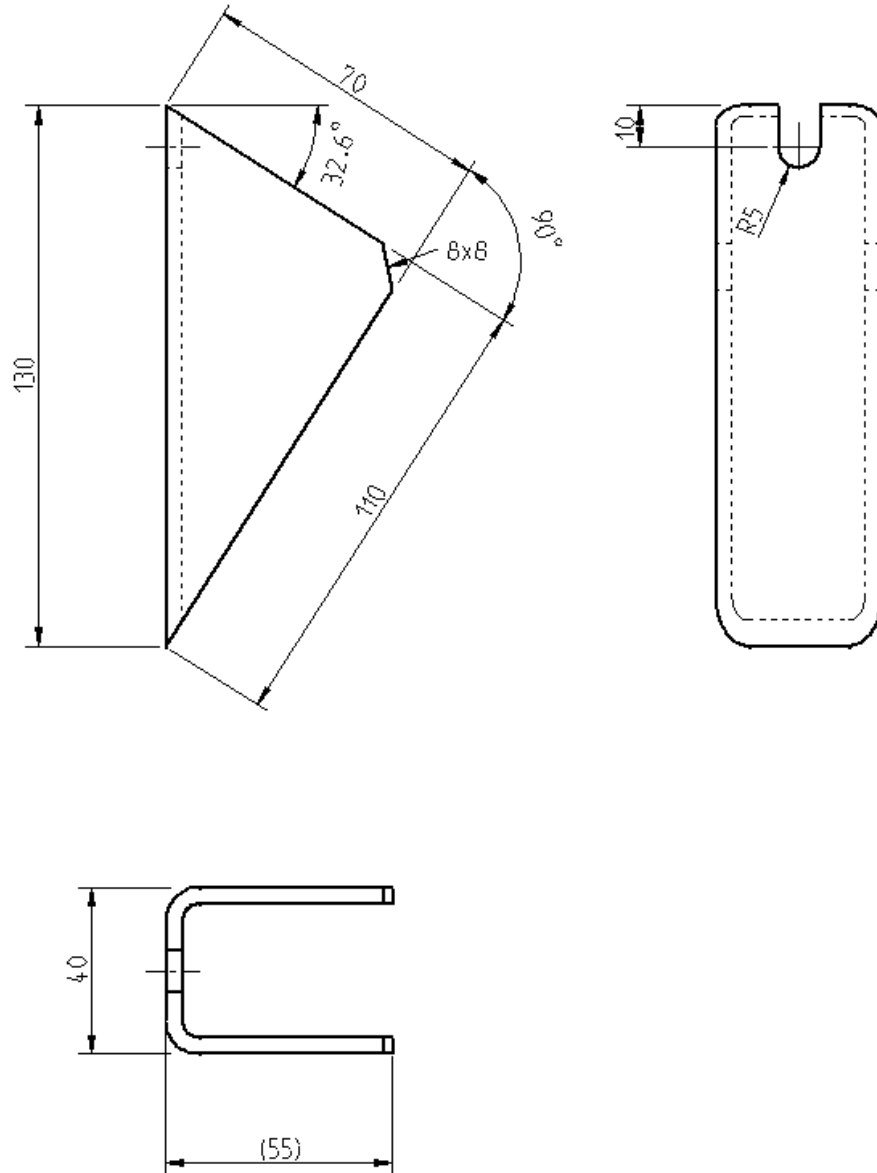

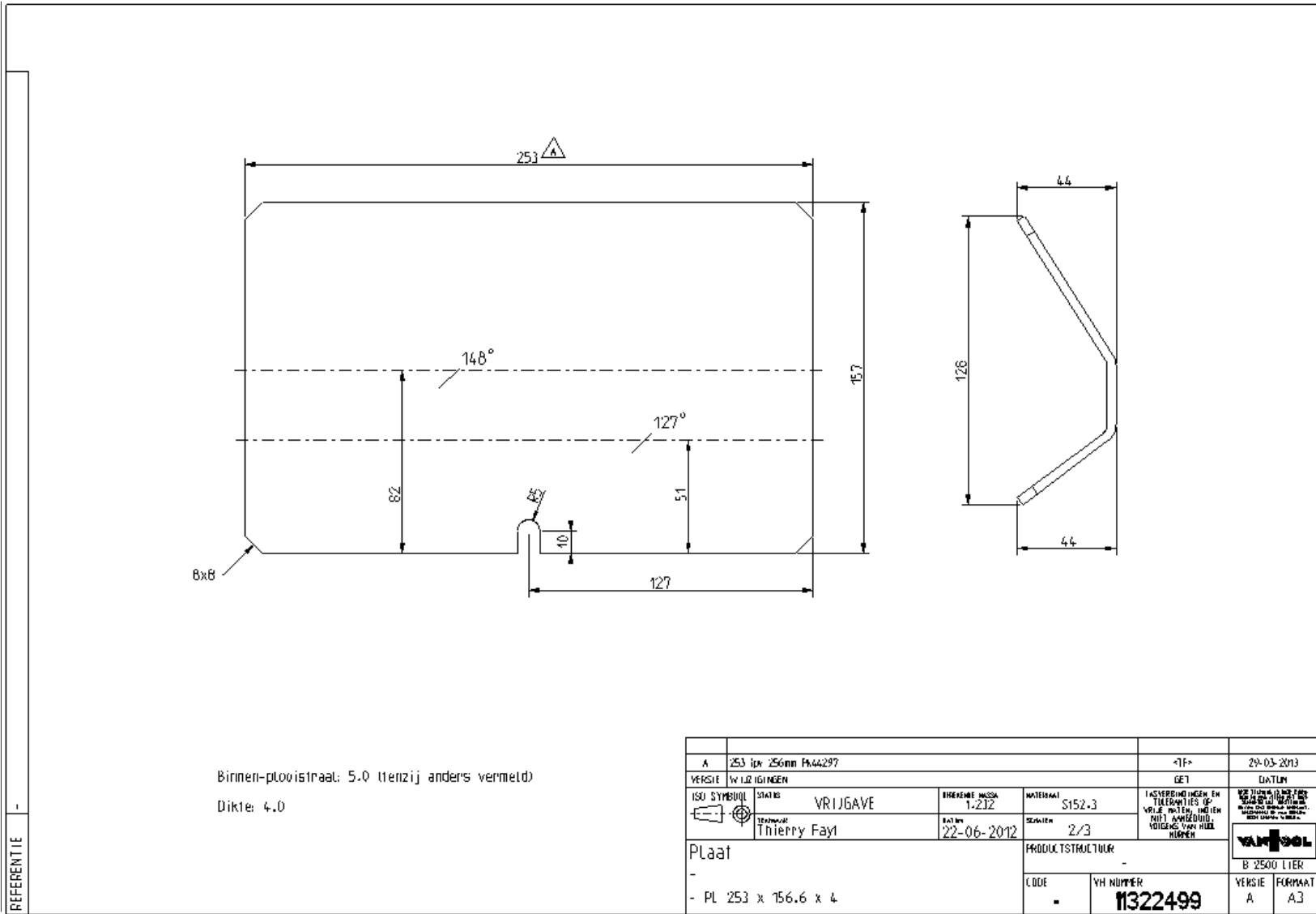

VERSIE		W IJZ IGINEN		GET		DATUM	
ISO SYMBOOL	STATUS	BEREKENDE MASSA	MATERIAAL	LASVERBINDINGEN EN TOLERANTIES OP VRIJE MATEN, INDIEN NIET AANGEDUID, VOLGENS VAN HOOL NORMEN		<small>DEE TEKENING IS OOK VERBODEN IN HANDELEN MET ENDE SCHEPSEL EN TOEGANGSRECHTEN. ALLE RECHTEN VOORBEREIDEN DOOR DEZELVE NIEMEN.</small> VANHOOL B 2500 LIER	
	TERENAAR Thierry Fayt	0.340	S137.2				
RHB S137.2 70x40x4 L=130 Bewerkt XXX		DATUM	SCHALEN	PRODUCTSTRUCTUUR		VERSIE	FORMAAT
-		22-06-2012	2/3	-		-	A4
-		-		CODE	VH NUMMER	-	
-		-		-	11322498	-	

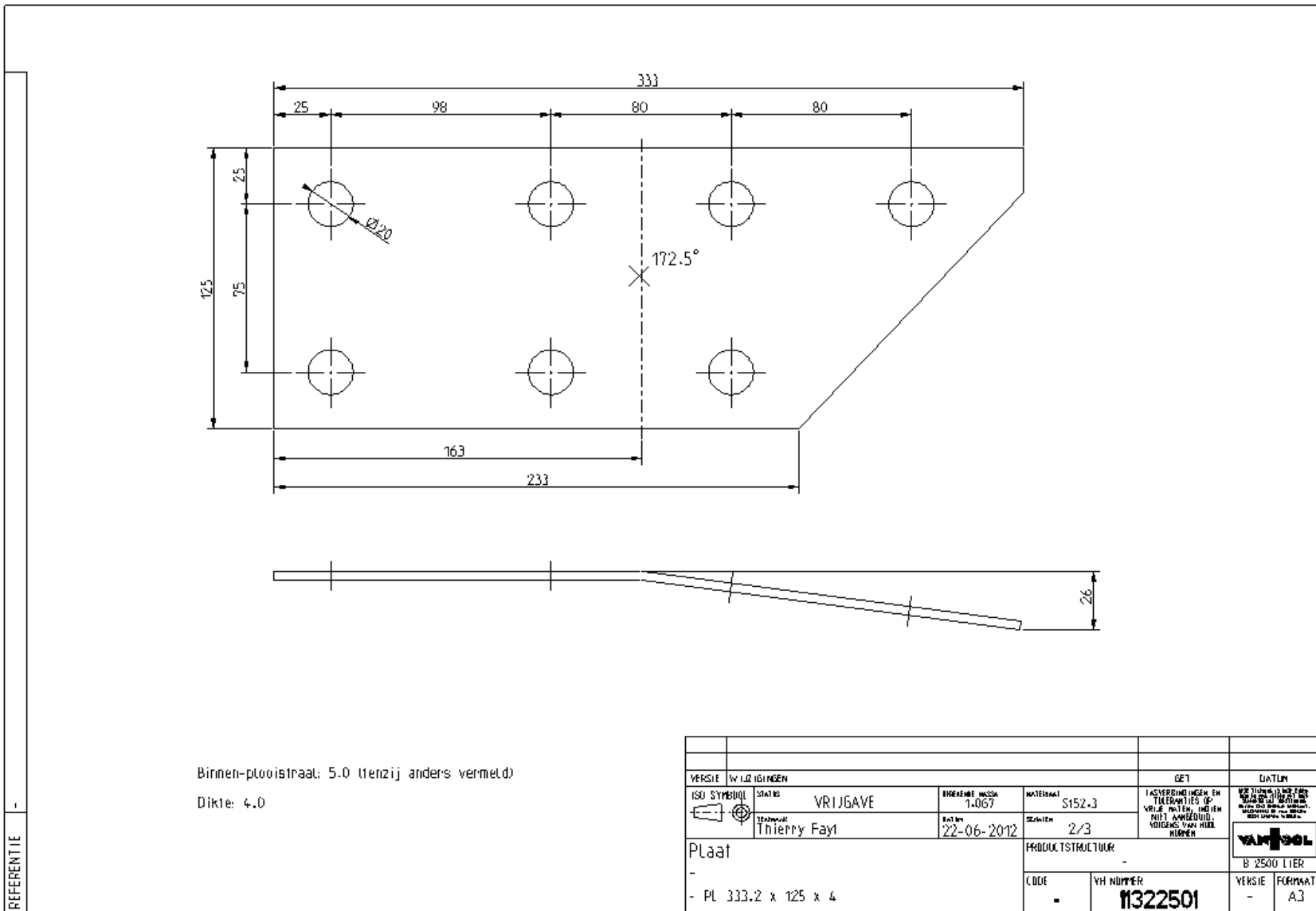



Binnen-plotstraal: 5.0 (tenzij anders vermeld)
 Dikte: 4.0

REFERENTIE

VERSIE		WIJZIGINGEN		GET		DATUM	
ISO SYMBOOL	STATUS	BREKENE MASSA	MATERIAAL	LASVERBINDINGEN EN TILERANTIES OP WELKE PUNTEN, HOELEN (NIET) AANGEWIJZD, VOIGENDS VAN HIER NIETEN		 B 2500 LITER	
	VRIJGAVE	1.067	S152-3				
	Technisch: Thierry Fayt	Datum: 22-06-2012	Scale: 2/3	PRODUCTSTRUCTUUR		VERSIE	
Plaat				-		FORMAAT	
- PL 333.2 x 125 x 4				CODE		VH NUMMER	
				-		11322501	
						-	
						A3	

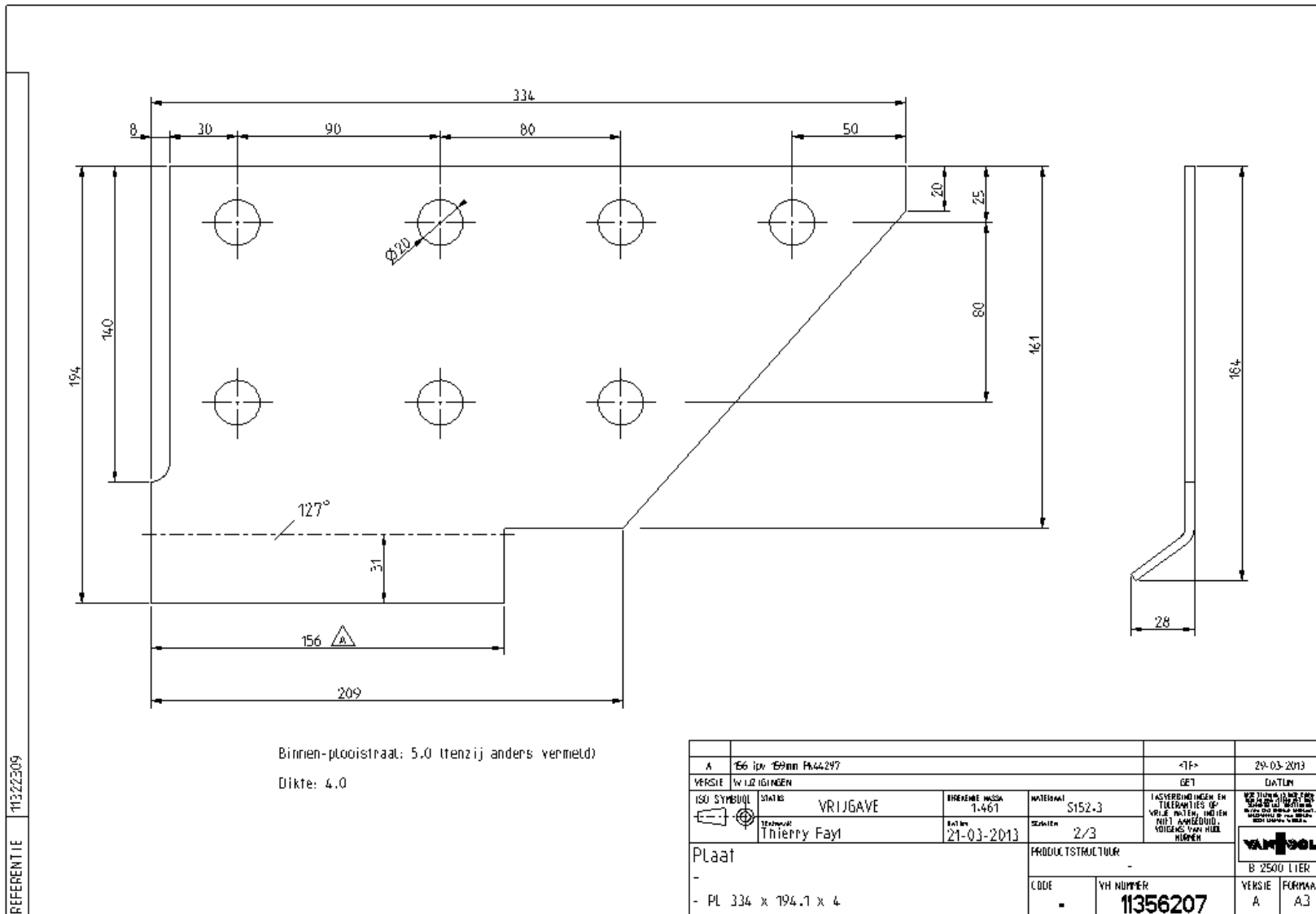

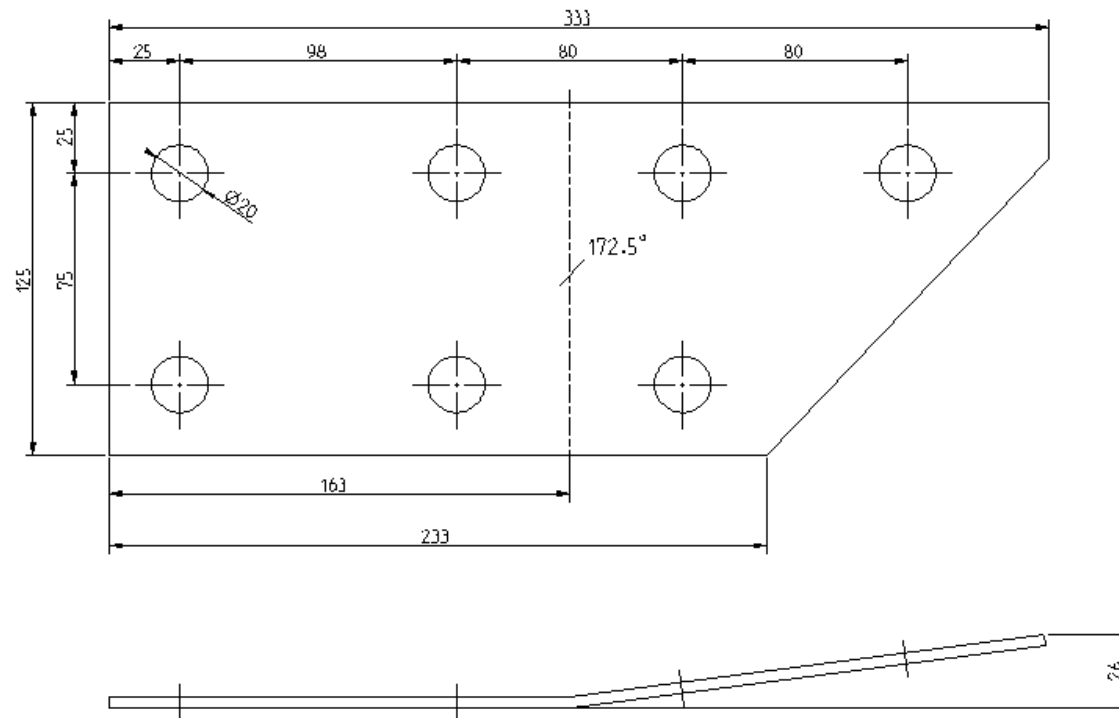

REFERENTIE 11322501



Binnen-plooistraal: 5.0 (tenzij anders vermeld)

Dikte: 4.0

VERSIE		WIJZIGINGEN		GET		DATUM	
ISO SYMBOOL	STATUS	BREKENE MASSA	MATERIAAL	IJSVERBINDINGEN EN TILBEREIDINGEN OP WOLVE, PASTEN, HEDLEN NIET AANGEWIJZD. VOIGENS VAN HULP NIEUWEN		 B 2500 LITER	
	VRIJGAVE	1.066	S152-3				
	Thierry Fayt	Datum	21-03-2013	FRIDUCTSTRUCTUUR			
Plaat				CODE	VH NUMMER	VERSIE	FORMAAT
- PL 332.7 x 125 x 4				-	11356215	-	A3