

<b>ADDRESSEES</b>	: ABC Customer Care and Parts Source
<b>VEHICLE MODEL</b>	: C2045, T2100, CX45, CX35
<b>SYSTEM/SUBSYSTEM</b>	: 08.14 Climate control – Condenser
<b>BULLETIN TYPE</b>	: Service Information
<b>DATE</b>	: May 24, 2016
<b>SUBJECT</b>	: <b>To change condenser fan relay 660752034 by relay 660752200</b>
<b>TERMS &amp; CONDITIONS</b>	: -

### DESCRIPTION:

The condenser fans are switched by relay K21M. Two versions of this relay have been used in production: earlier coaches have a 50 amp relay fitted (VH660752034); current coaches are equipped with a 150 amp relay (VH11374693). Whenever a malfunctioning 50 amp relay is replaced, it is recommended to use the 150 amp version as a service replacement part. The procedure is explained in Service Bulletin SB1306.

Customers who have a zinc plated cylinder type relay VH660752200 in stock can use this relay as an alternative for the 150 amp relay. The procedure is explained in this Service Bulletin.

Old and new parts are interchangeable, provided minor modifications are made. Please refer to the material list and step-by-step procedure for modification instructions.

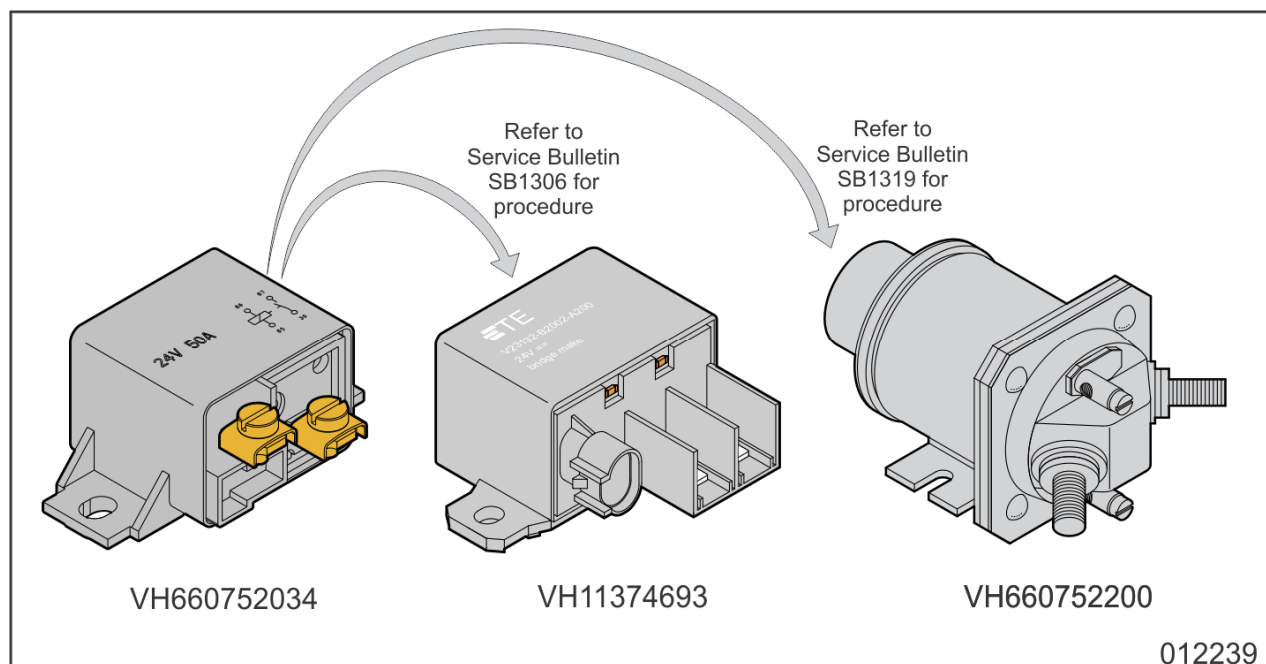

**Figure 1: Condenser fan relay types**

*Continued on next page.*

## **MATERIAL:**

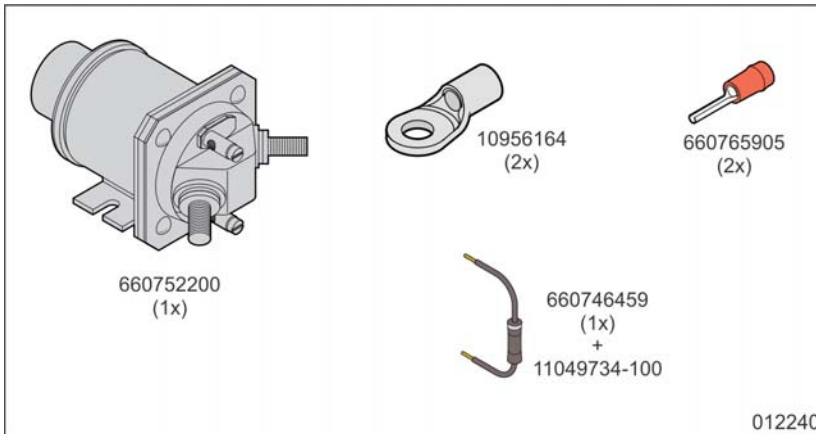

**Figure 2**

VH reference	Description	Qty.
660752200	Relay (80A)	1
10956164	Ring terminal (M8/16mm <sup>2</sup> )	2
660777436-100	Shrink tubing for ring terminal 10956164 (red)	1
660765905	Pin terminal	2
11049734-100	Shrink tubing for insulation of diode wires (black)	1
660746459	Diode	1

- Material may be purchased through regular channels.
- Parts/Waste disposal: discard old material according to applicable environmental regulations.

## **PROCEDURE:**

### **1. General:**

- This job has to be carried out by a technician proficient in automotive electrics.
- If you do not have the expertise to carry out present procedure, do not hesitate to go to your nearest ABC Customer Care & Parts Source service center.

### **2. Special tools, equipment or services:**

This job does not require special tools, equipment or services.

### **3. Preparations:**

- Park the coach safely, apply the parking brake, stop the engine, switch off all systems and turn off the battery master switch. Turn off the mechanical battery switch.
- Read the entire procedure before beginning to work.



## **WARNING!**

Observe safe shop practices at all times.

*Continued on next page.*

### To change condenser fan relay K21M:

- 1) Locate the K21M condenser fan relay.
- 2) With cutter pliers, cut-off all wires attached to the K21M relay, as close as possible to the two ring terminals and the multi-wire connector.
- 3) Undo and remove the two screws securing relay 660752034. Remove the relay.
- 4) Secure replacement relay 660752200 from the kit to the switchboard.
- 5) Take diode 660746459 from the kit. Slide a piece of black heat shrink tubing from the kit on both diode wires. Make sure to have approximately 5 mm (0.2 inch) of the wire free of insulation. Insulate the diode wires by heating the shrink tubing. *The function of the diode is to protect the multiplex system node against possible induction voltages generated during relay switching*
- 6) **For the red wires:** slide a piece of red heat shrink tubing from the kit on both red wires. Strip back the wires. With a crimping tool, fit ring terminal 10956164 from the kit to both red wires. Insulate the ring terminal bodies by heating the shrink tubing. Connect the red wires to the relay stud terminals.
- 7) **For the green wire:** strip back the green wire. Crimp the green wire together *with the wire of the diode located at the silver band side* to pin terminal 660765905 from the kit.
- 8) **For the brown wire:** strip back the brown wire. Crimp the brown wire together with the other wire of the diode to pin terminal 660765905 from the kit.
- 9) Connect the terminal with the green wire to connection #50 of the relay; the terminal with the brown wire to connection #31 of the relay.

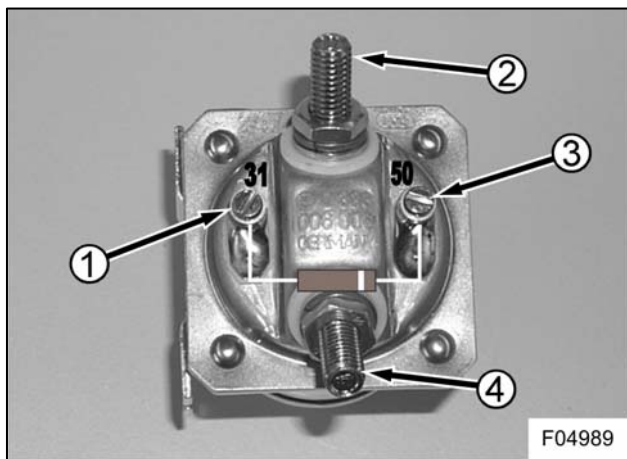

Figure 3: Relay connections

1. Brown wire to terminal #31
2. Red wire terminal (no mark)
3. Green wire terminal #50
4. Red wire terminal (no mark)

*Procedure complete.*

### DISCLAIMER:

The procedures contained herein are not exclusive. Van Hool cannot possibly know, evaluate, or advise the transportation industry of all conceivable ways in which a procedure may be undertaken or of the possible consequences of each such procedure. Other procedures may be as good, or better, depending upon the particular circumstances involved.

Each carrier who uses the procedures herein must first satisfy itself thoroughly that neither the safety of its employees or agents, nor the safety or usefulness of any products, will be jeopardized by any procedure selected.

*Continued on next page.*

### **INFORMATION HANDLING:**

Important supplements to and modifications of the technical information not yet included in the Van Hool manuals are communicated by means of Service Bulletins.

File the Service Bulletins at the back of your manual, in numerical order.

To make sure that you will be reminded of the Bulletins that have appeared in the meantime while paging the manual, mark the pages concerned by hand with the Service Bulletin number.

### **VAN HOOL CUSTOMER PORTAL:**

Consult the Van Hool customer portal for the latest service documentation. Beside the maintenance manual, you will also find the operating manual and the spare parts catalogue of your vehicle on the customer portal. The customer portal is accessible through [www.vanhool.be](http://www.vanhool.be) under “service” menu item, and only with a code (password) from Van Hool. If you do not have a password yet, request it by using the above link.