

ADDRESSEES	: ABC Customer Care and Parts Source Owners and operators of coaches listed under "Application"
VEHICLE MODEL	: All coaches
MANUAL CHAPTER	: 02.46 Traction engine - accessory drive system
BULLETIN TYPE	: Product improvement
DATE	: August 26 th , 2016
SUBJECT	: Introduction of new bearing for fan-drive idler pulley
TERMS & CONDITIONS	: This service bulletin does not entitle to any reimbursement.

APPLICATION:

As from following units with EPA2016 engine, Van Hool has improved the fan-drive idler pulley installation.

Model	VIN
CX35	49270
CX45 Cummins	49190
CX45 Detroit Diesel	49159
TX45 Cummins	41391
TX45 Detroit Diesel	41335
TD925US Cummins	42920
TD925US Detroit Diesel	42889
TDX25US Cummins	42919

DESCRIPTION:

The cooling fan is driven from the engine crankshaft pulley by V-belts. The drive is provided with a tensioning device to make belt tension adjustment possible. As from units with EPA2016 engine onwards, Van Hool has switched to an improved bearing installation for the fan-drive idler pulley. The new construction contains:

- new ball bearings (rubber sealing resistant to temperatures up to 390°F; grease resistant to temperatures up to 300°F);
- supplemental protection cap to prevent direct water penetration when using a pressure washer;
- a M14 fixing bolt instead of M12.

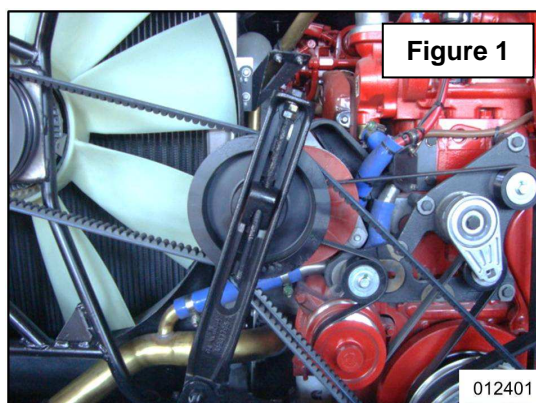

New parts are supplied as a Bearing Kit, #11496230 and a Pulley Kit, #11514152. This Service Bulletin gives step-by-step bearing installation instructions. Both kits will fit earlier units prior to the unit numbers listed above.

Continued on next page.

COMPONENTS AND PRODUCTS:

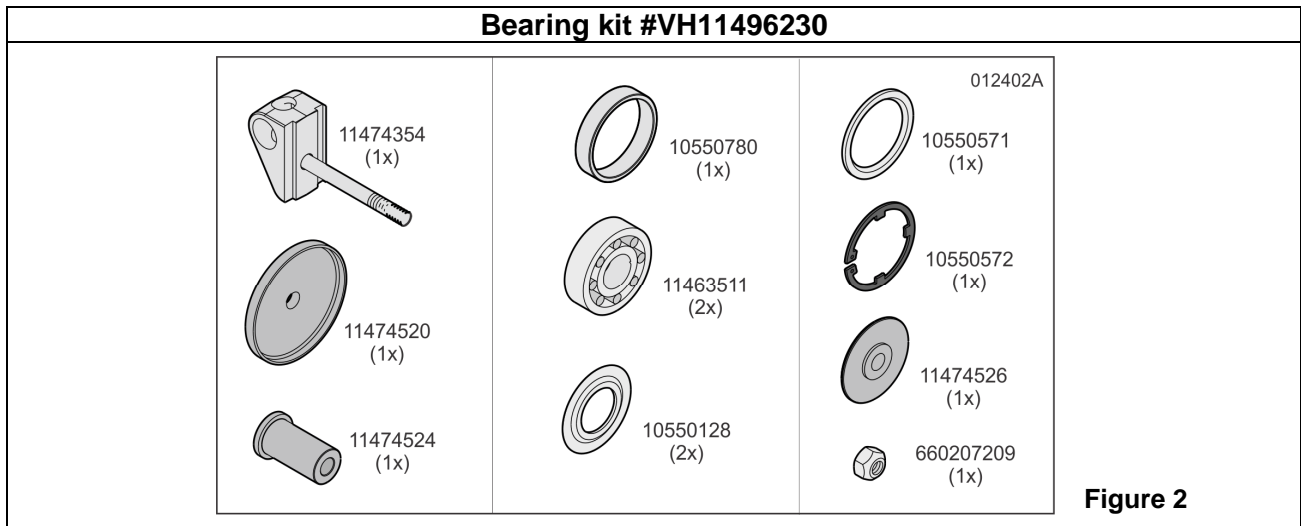

Figure 2

VH reference	Description	Quantity
11474354	Fixing screw	1
11474520	Protection cap	1
11474524	Bearing bush	1
10550780	Spacer	1
11463511	Ball bearing	2
10550128	Dust shield	2
10550571	Special washer	1
10550572	Circlip	1
11474526	Cover disk	1
660207209	Nut	1

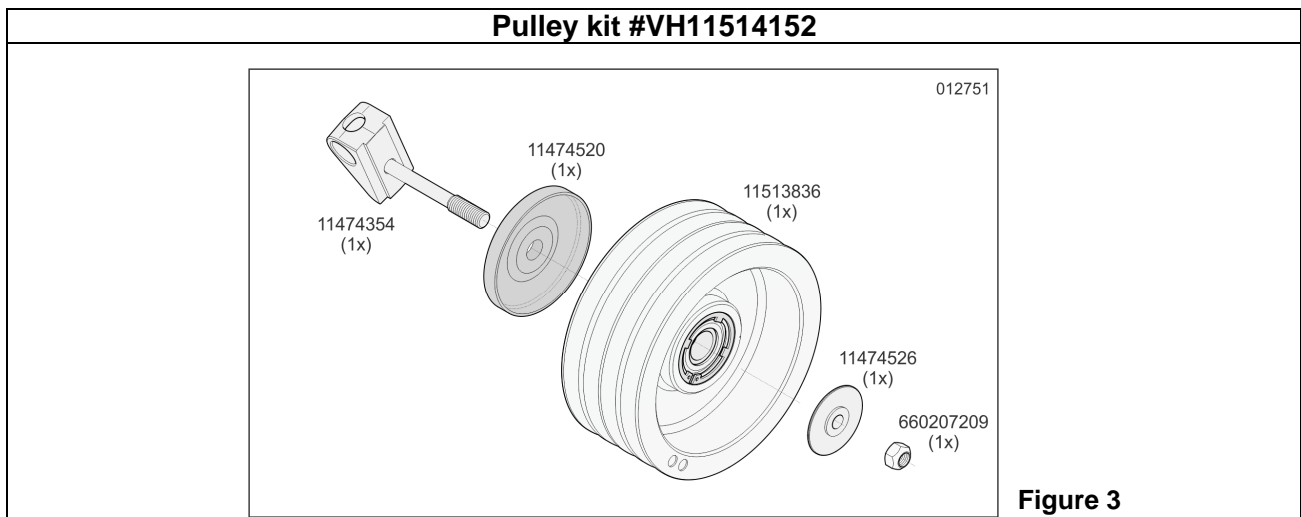

Figure 3

VH reference	Description	Quantity
11474354	Fixing screw	1
11474520	Protection cap	1
11513836	Pre-assembled idler pulley	1
11474526	Cover disk	1
660207209	Nut	1

Continued on next page.

JOB QUALIFICATION:

This task has to be carried out by an experienced automotive technician, trained in the operations at hand.

SPECIAL TOOLS:

Drift: VH10616471 (only necessary when replacing a bearing kit in an existing pulley. Refer to figure 4 for tool identification)

PREPARATIONS:

- Open the mechanical battery isolation switch.
- Put a "DO NOT START" warning message on the instrument panel before starting the works.
- Put chocks in front of and behind the drive axle wheels.
- Read the entire procedure before starting to work.



WARNING!

Observe safe shop practices at all times.

PROCEDURE TO REPLACE BEARINGS - Figure 4:

Step	Action
1	Remove the pulley assembly from the tensioner bracket.
2	Remove snap ring (10) from the outer bearing side of the pulley.
3	Position the pulley with the snap ring side down on a flat surface and support it in a way that bearing removal is possible. With a suitable drift, press out the bearing assemblies.

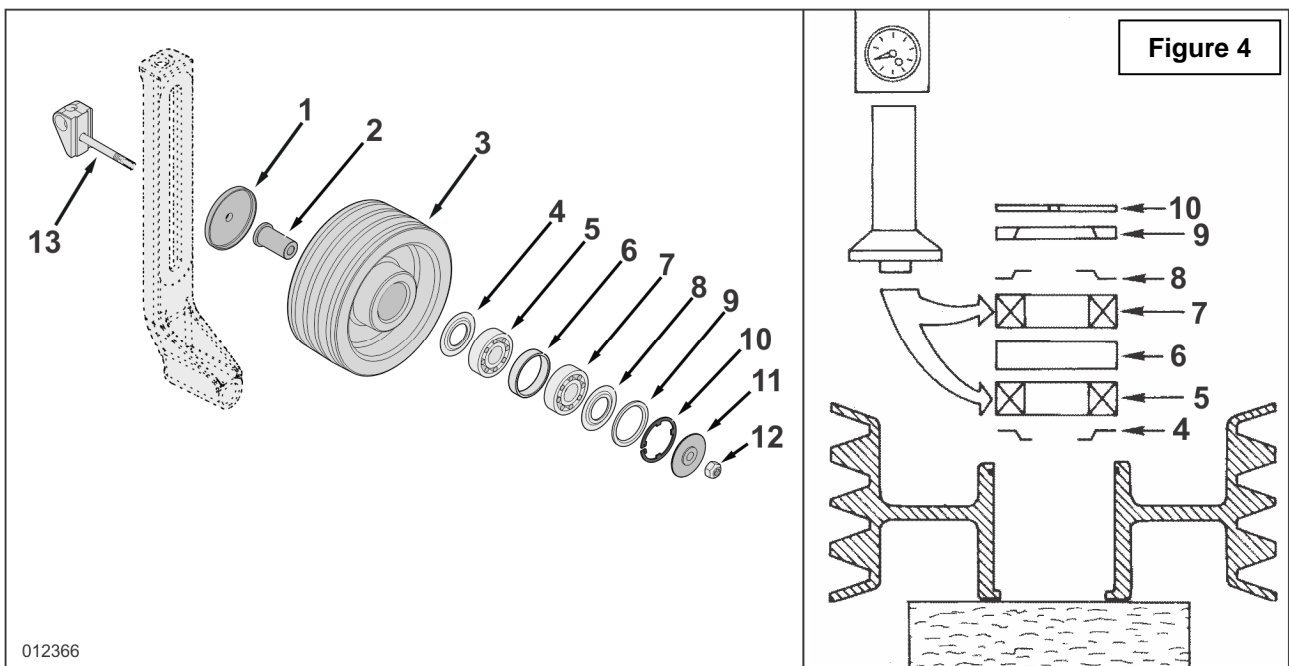

Continued on next page.

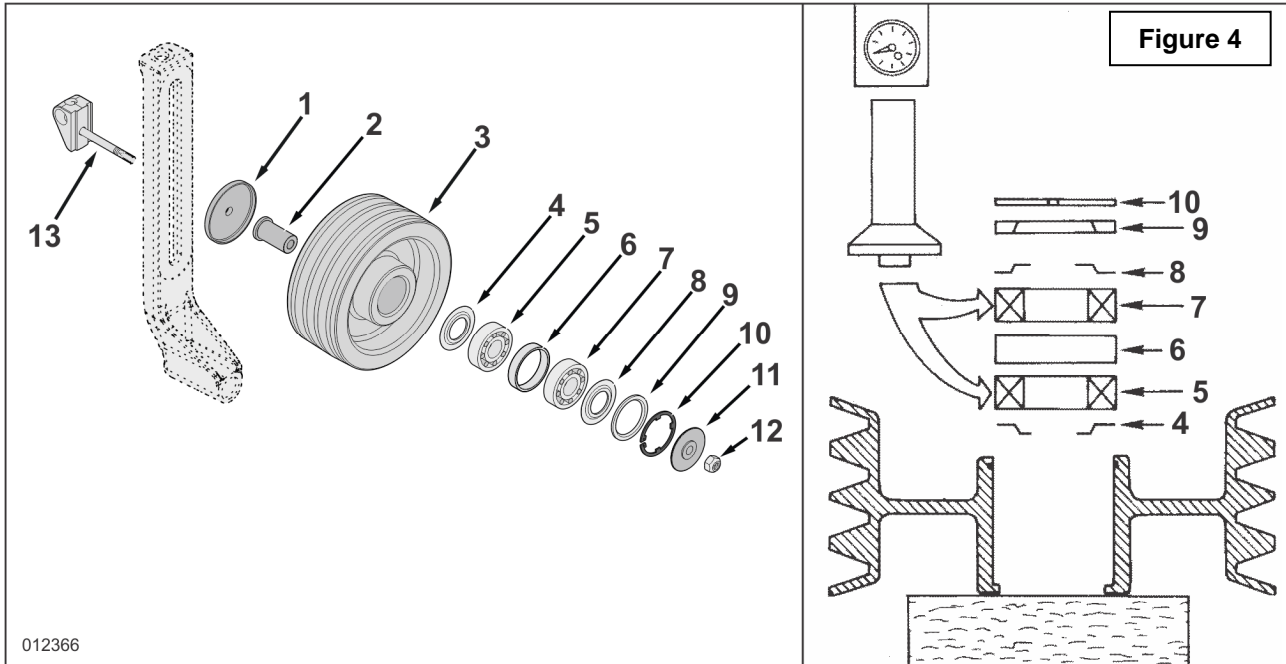

4	Clean the inner surface of bearings (5) and (7) as well as the exterior shell of bearing bush (2), and the inner surface of the pulley with Loctite 7061.
5	Install pulley (3) on a wooden block as shown.
6	Insert dust shield (4) as shown.
7	Press in bearing (5) by using drift VH10616471.
8	Install spacer (6).
9	Press in bearing (7) by using drift VH10616471.
10	Insert dust shield (8) as shown.
11	Install special washer (9) as shown.
12	Install snap ring (10). The snap ring must fully engage in the corresponding groove.
13	Apply Loctite 603 to the inner surface of both ball bearings as well as on the exterior shell of bearing bush (2). Make sure that the Loctite 603 is spread evenly over the surfaces.
14	From the opposite side of the snap ring, slide bearing bush (2) in the pulley. Remove the surplus Loctite 603 with a cloth.
15	Allow the Loctite 603 to dry. Recommended waiting time at ambient temperature above 20°C: at least 6 hours.
16	Slide protection cap (1) with the pre-assembled pulley and cover disk (11) on fixing screw (13). Install nut (12) and tighten it with a torque of 125 ± 15 Nm (90 ± 10 ft.lbf).

Procedure complete

Continued on next page.

INFORMATION HANDLING:

Important additions and modifications regarding technical information not yet included in the manual will be communicated through Service Bulletins.

VAN HOOL CUSTOMER PORTAL:

Consult the customer portal regularly for the latest service documentation. Beside the maintenance manual, you will also find the operating manual and the spare parts catalogue of your vehicle on the customer portal. The customer portal is accessible through www.vanhool.be, and only with a code (password) from Van Hool. If you do not have a password yet, request it by using the link on the Van Hool website.