

| | |
|-------------------------------|--|
| ADDRESSEES | : ABC Customer Care and Parts Source Owners and operators of coaches listed under "Application" |
| VEHICLE MODEL | : TD925US, TDX25US |
| MANUAL SECTION | : 14.10 Electricity – wiring |
| BULLETIN TYPE | : Field Change Program |
| DATE | : June 22nd, 2017 |
| SUBJECT | : To check position of rear junction box grid |
| TERMS & CONDITIONS | : Refer to the warranty section further in this Bulletin. |

APPLICATION:

The Field Change Program, subject of this bulletin, is applicable to some vehicles of the below mentioned models:

| | |
|---------|---------|
| TD925US | TDX25US |
|---------|---------|

DESCRIPTION:

There is a possibility that the grid of the rear junction box is not properly positioned with respect to the surrounding covers. The side cover can prevent the circuit breakers from tripping off in case of an overload or shorted circuit. Owners and operators should first check the position of the grid, and change if necessary.

This Service Bulletin gives step-by-step instructions to reposition the rear junction box grid.

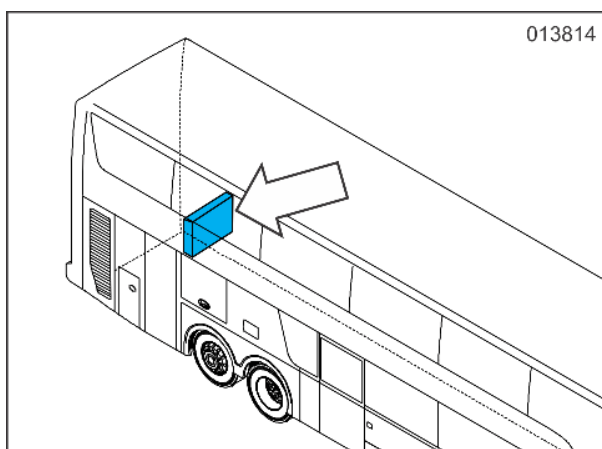

Figure 1: Location of rear junction box

Continued on next page.

COMPONENTS AND PRODUCTS:

No special components or products are required.

JOB REQUIREMENTS:

Job technician's qualifications/experience: electricity.

SPECIAL TOOLS, EQUIPMENT OR SERVICES:

No special tools or equipment or services required.

PREPARATIONS:

- Park the coach on a level-surfaced service pit.
- Apply the parking brake and shut down the engine.
- Switch off all systems and turn off the battery master switch.
- Turn off the mechanical battery switch.
- Put a "DO NOT OPERATE" tag on the instrument panel.
- **Read the entire procedure before beginning to work.**



WARNING!

Observe safe shop practices at all times.

PROCEDURE:

| Step | Action |
|------|---|
| 1 | Locate rear junction box in the luggage compartment. |
| 2 | Remove front cover (2) of the junction box.  |

Figure 2: Rear junction box

1. Side cover
2. Front cover

Continued on next page.

| | |
|-----------------|---|
| <p>3</p> | <p>Check clearance “A” between side cover (1, figure 2) and circuit breakers.</p> <p>Is distance “A” less than 20 mm (0.7 inch)?</p> <ul style="list-style-type: none"> • If so, proceed with step 4. • If not, register through the registration button located behind Service Bulletin SB1438 on the Van Hool customer portal. Write the text "Junction box grid position checked, position OK" in the field "Remark". Labor allowance will only be awarded after Van Hool has received the registration. No further action is required. <div data-bbox="544 477 1142 913" data-label="Image"> </div> <p style="text-align: right;">013809 Figure 3</p> |
| <p>4</p> | <p>Reposition the junction box grid as follows:</p> <ol style="list-style-type: none"> Remove the screws securing the grid to the wall. Reposition the grid until the clearance between the circuit breakers and the side panel is sufficient. Secure the grid again. <div data-bbox="544 1149 1142 1585" data-label="Image"> </div> <p style="text-align: right;">013810 Figure 4: Position of grid fixing screws (example)</p> |
| <p>5</p> | <p>Install the covers of the junction box.</p> |
| <p>6</p> | <p>Register through the registration button located behind Service Bulletin SB1438 on the Van Hool customer portal. Write the text "Junction box grid position changed" in the field "Remark". Labor allowance will only be awarded after Van Hool has received the registration.</p> |

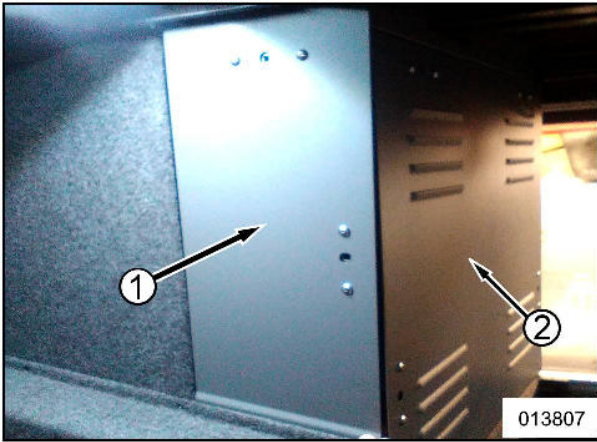
End of procedure

Continued on next page.

WARRANTY:

1. Conditions

Van Hool accepts claims for this conversion as follows:

Compensation for labor hours:

- 0.5 (half) hour for checking junction box grid position
- 1 hour for checking and changing junction box grid position

Campaign target date: Service Bulletin issue date + 0,5 year

2. Claim references:

- **Job code:** O61438N
- **Causal part:** 11495807
- **Claim submission:** Contact ABC Customer Care Warranty Department for guidance.
- **Monitoring and performance:** The claim records pertaining to this Bulletin will be used to determine that the remedy has been executed in accordance with the manufacturer's instructions and to evaluate the status of this Field Change Program.

INFORMATION HANDLING:

Important additions and modifications regarding technical information not yet included in the manual will be communicated through Service Bulletin.

VAN HOOL CUSTOMER PORTAL:

Consult the customer portal regularly for the latest service documentation. Beside the maintenance manual, you will also find the operating manual and the spare parts catalogue of your vehicle on the customer portal. The customer portal is accessible through www.vanhool.be, and only with a code (password) from Van Hool. If you do not have a password yet, request it by using the link on the Van Hool website.